



Eltra[®]

INCREMENTAL ENCODERS index

Shaft incremental encoder

EL 30 E / H / I	4
EH 38 A / B / D	6
EL 40 A / B / C / E / H / I	8
EH - EL58 B / C / H / T	10
EH - EL63 A / D / E	12
EH - EL90 A - R / 115 A - R	14

Hollow shaft incremental encoder

Please note: models marked with * are
available with Hall Phases

*EF36 K	16
EL38 F / G	18
EL40 G / GR	20
EL / *EF / EW48 C - P	22
EL / *EF 49 C - P	24
EL50 F / G / K	26
EL50 FA / GA / FP / GP	28
EH - EL 53 A / B	30
EH - EL 58 / 63	32
EH - EL 72 A / B	36
EH - *EF80 C / P / K	38
EL88 P	40
EL120 P	42
EL150 P	44

Special products

Explosionproof incremental encoder	EX80 A / D	46
Incremental encoder for racks	EC34	48
Metric wheels	RH200 A / B / C - RH - RM500 A / B / C	50
Incremental linear system	ER A / B / C	52
Electronic hand wheel	EV A / B / C	54
Rope encoder	FE	56
Magnetic incremental linear sensor	ETMA	60
	EBM	62
Potentiometer	EP A / B	64
Boards	EMB	66
	EMD	68
Accessories	Couplings	70
Output configurations		72
Output connections		74
Installation and operation precautions		76



INCREMENTAL ENCODER GENERAL DESCRIPTION



Working principle

An encoder is a rotational transducer converting an angular movement into a series of electrical digital pulses. If associated to racks or endless screws, these generated pulses can be used to control angular or linear movements. During rotation, electrical signals can be elaborated by numerical controls (CNC), programmable logic controls (PLC), control systems, etc. Main applications of these transducers are: machinery, robots, motor feedback, measure and control devices. In Eltra's encoders the angular movement transduction is based on the photoelectric scanning principle. The reading system is based on the rotation of the radial graduated disk formed by opaque windows and transparent ones alternated. The system is perpendicularly illuminated by an infrared light source. The light projects the disk image on the receivers surface which are covered by a grating called collimator having the same disk steps. The receivers transduce the light variation occurring with the disk shifting, converting them into their corresponding electrical variations. Electrical signals raised to generate squared pulses without any interference must be electronically processed. The reading system is always carried out in differential modality, in order to compare different signals nearly identical but out of phase for 180 electrical degrees. That in order to increase quality and stability of output signals. The reading is designed comparing the difference between the two channels eliminating the disturb note as "shifted common way" because signals are overlapped in equal way on every kind of wave.

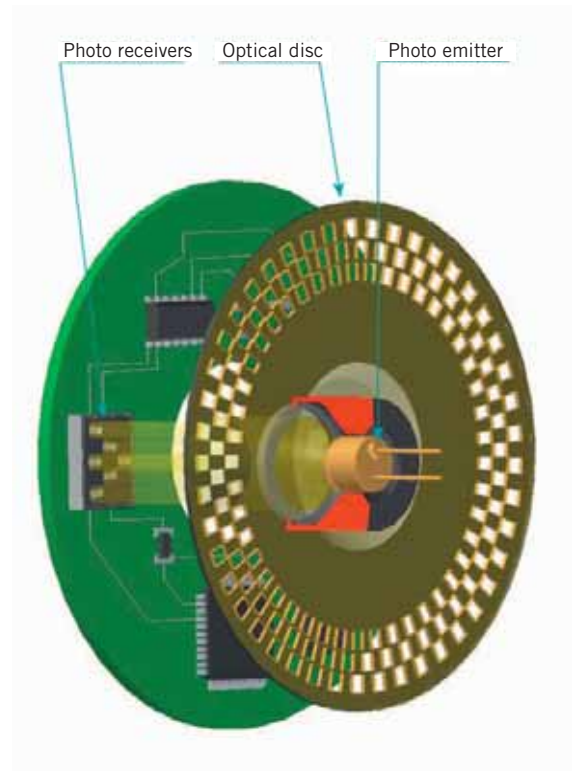

Incremental encoders

The incremental encoder usually gives two types of squared waves out of phase for 90 electrical degrees. They are usually called channel A and B. The first channel gives information about the rotation speed while the second, basing on the states sequence produced by the two signals, provides the sense of rotation. A further signals, called Z or zero channel, is also available. It gives the absolute zero position of the encoder shaft. This signal is a squared impulse with the phase and the width centred on A channel.

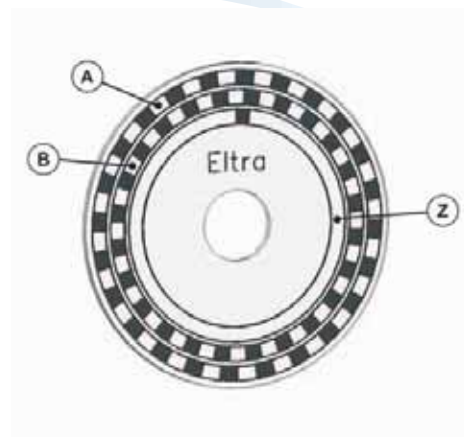

The incremental encoder precision depends on mechanical and electrical factors. These errors could be: grating division, disk eccentricity, bearings eccentricity, electronic reading and optic inaccuracy. The measurement unit to define encoder precision is the electrical degree. It determinates the division of the impulse generated by the encoder: 360 electric degrees correspond to the mechanical rotation of the shaft which is necessary to carry out a complete cycle. To know how many mechanical degrees correspond to electrical 360° the following formula has to be applied:

$$\text{Electrical } 360^\circ = \frac{\text{Mechanic } 360^\circ}{n^\circ \text{ pulse / turn}}$$

The encoder division error is given from the maximum shifting shown in the electrical degrees of two consecutive surges. This error exists in any encoder and is due to the above mentioned factors. For Eltra's encoders this error is included in electrical +/- 25° Max in whatever allowed condition, which corresponds to a shifting of +/- 7 % from the nominal value. Regarding the 90 electrical degrees shifting between the two channels, it differs by +/- 35 electrical degrees Max. It corresponds to +/- 10 %.

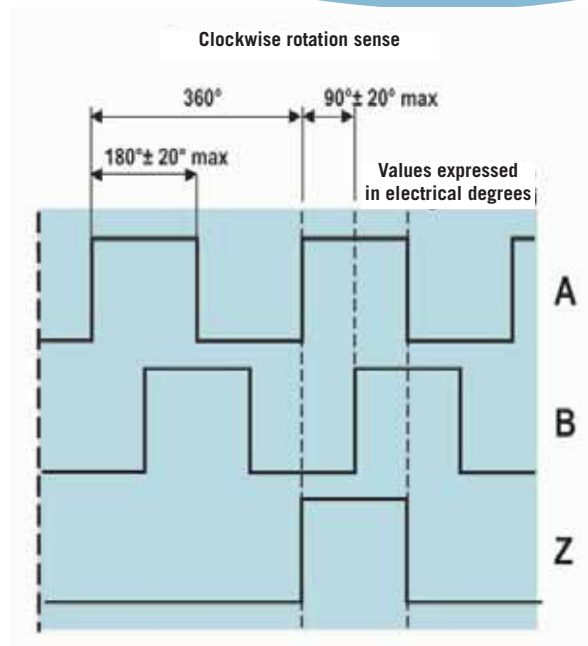

Graphic representation of the A, B and Z incremental signals.

Incremental encoder with integrated commutation phases

In addition to the above mentioned encoders, there are others which integrate additional electrical output signals. These are the incremental encoders with integrated commutation signals, used as motor feedback. These additional signals simulate the Hall phases generally present in the commutation motors (brushless type) and usually designed with magnetic sensors. In Eltra's encoders these commutation signals are optically generated and presented as three squared waves, shifted by 120° electrical degrees. These signals will be used by the driver control to the motor in order to generate the correct voltages phase to determinate the correct rotation. These commutation pulses can be repeated many times within one mechanical rotation because they directly depend on the poles number in the connected motor. So we have commutation phases for motors of 4, 6 or more poles.

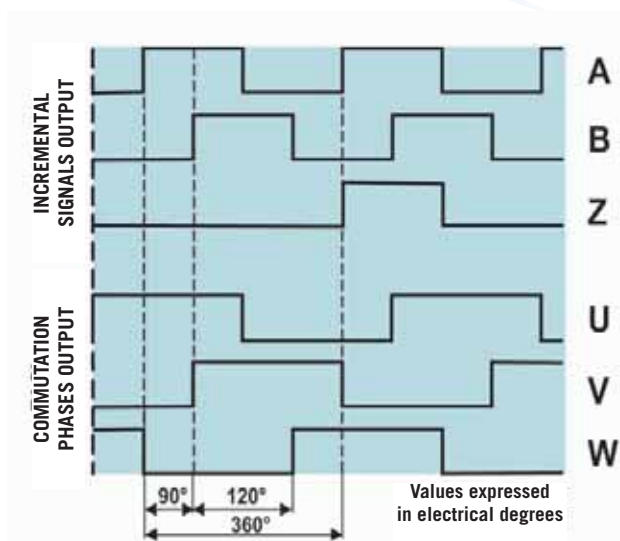

Graphic representation of A, B and Z incremental signals with commutation U, V and W.

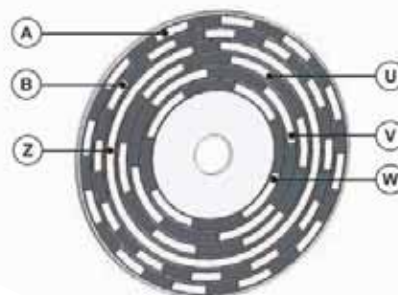



EL30 E/H/I INCREMENTAL ENCODER



Incremental encoder

Miniaturized Ø30 encoder series. Used when a minimal size is required even providing excellent performances.

- Up to 1024 ppr with Zero.
- Several output types available. Up to 24 Vdc input voltage.
- Up to 100 kHz frequency response
- Output cable. Cable connector available on request.
- Several flanges available
- Up to 3.000 rpm speed rotation
- Up to IP54 sealing



shaft INCREMENTAL ENCODERS

Ordering code

Full stop to separate special version

EL	30	E	50	Z	5	N	4	X	3	P	A	XXX
incremental encoder series	body dimension	Type of flanges							R.P.M.	Enclosure rating	A axial	Special version code numbered from 001 to 999
		mod.EL 30 E E							3 3000	X standard IP54		
		mod.EL 30 H H									P cable output (standard length 0,5 m)	
		mod.EL 30 I I										
			Resolutions									
			From 1 to 1024 PPR									
			<i>Please, directly contact our offices for pulses availability</i>									
			Zero pulse									
			without zero pulse S									
			with zero pulse Z									
			Input voltage									
			5									
			8 ÷ 24									
			Output types									
			N NPN									
			C NPN OPEN COLLECTOR									
			P PUSH PULL									
			L LINE DRIVER									
			<i>For optionals about output types please refer to incremental section</i>									

EL30 E / H / I

EL 30 E

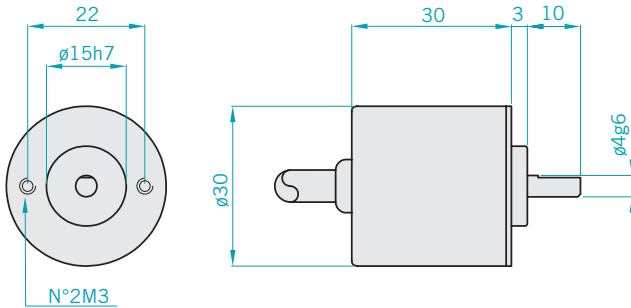

Electrical specifications

Resolution	From 1 to 1024 PPR
Input voltage	5Vdc / 8 ÷ 24 Vdc
Input current with no output load	100 mA Max
Source and sink current	50 mA for channel 20 mA for channel with LINE DRIVER
Output types	NPN / NPNOPEN COLLECTOR / PUSH PULL / LINE DRIVER
Output frequency	100 KHz Max
Frequency response	$F = \frac{\text{RPM} \times \text{Resolution}}{60}$

EL 30 H

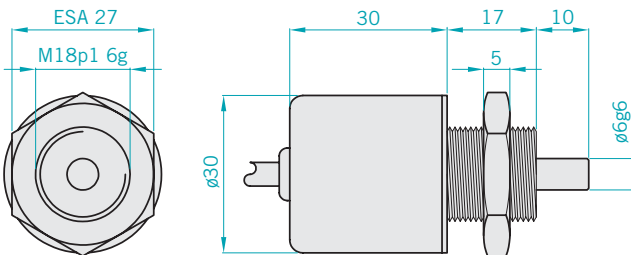

Mechanical specifications

Shaft diameter	ø4 mm g6 EL 30 E ø6 mm g6 EL 30 H/I/E
Enclosure rating	IP54 standard
Shaft speed	3000 RPM
Max shaft load	5N (0.5 Kp) axial 5N (0.5 Kp) radial
Shock	50 G for 11 msec
Vibrations	10G 10 ÷ 2000 Hz
Bearings life	10 ⁹ revolutions
Bearings	n° 2 Ball bearings
Shaft material	Stainless steel AISI303
Body material	Aluminium D11S - UNI 9002/5
Housing material	PA 66 reinforced with fiber glass
Operating temperature	0° ÷ +60°C
Storage temperature	-25° ÷ +70°C
Weight	50 g

EL 30 I

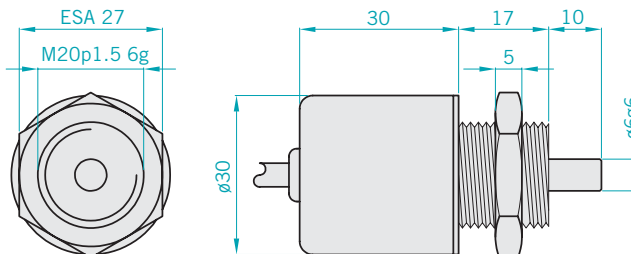



EH38 A / B / D INCREMENTAL ENCODER



Incremental encoder

- Miniaturized encoder series for general applications.
- Up to 1024 ppr.
- Several output types available.
- Up to 24 Vdc input voltage.
- Up to 100 kHz frequency response
- Output cable. Cable connector available on request.
- Several flanges available
- Up to 3.000 rpm speed rotation
- Up to IP54 sealing



shaft INCREMENTAL ENCODERS

Ordering code

Full stop to separate special versions												
EH	38	A	500	Z	5	N	6	X	3	P	R	XXX
incremental encoder series	body dimension	Type of flange	Resolution	Zero pulse	Input voltage	Output types	Shaft diameter	Enclosure rating	R.P.M.	cable output (standard length 0,5 m)	radial	Special version code numbered from 001 to 999
		mod.EH 38 A mod.EH 38 B mod.EH 38 D	From 40 to 1024 PPR <i>Please, directly contact our offices for pulses availability</i>	without zero pulse with zero pulse	5 8 ÷ 24	N NPN C NPN OPEN COLLECTOR P PUSH PULL L LINE DRIVER <i>For optionals about output types please refer to incremental output section</i>	6 ø 6 g6	X standard IP54	3 3000	P	R	

EH38 A / B / D

EH38 A

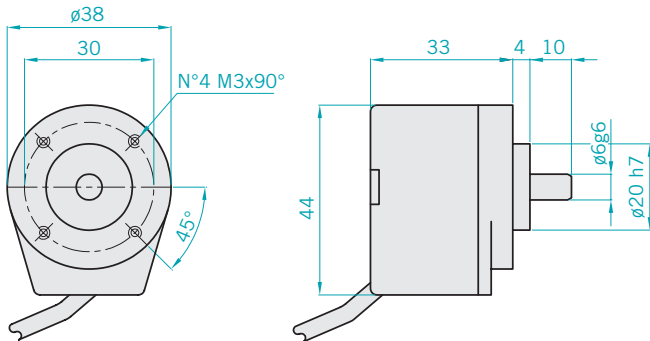

EL38 B

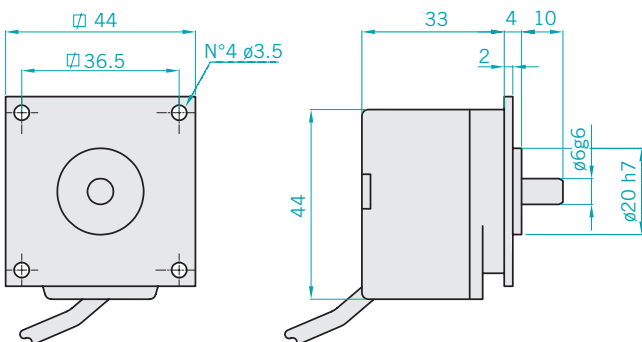

EH38 D

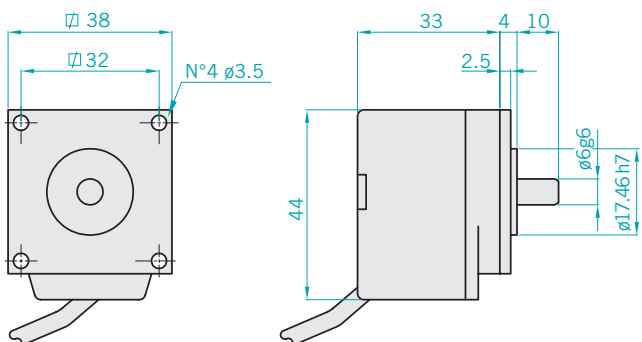

Electrical specifications

Resolution	From 40 to 1024 PPR
Input voltage	5Vdc / 8 ÷ 24 Vdc
Input current with no output load	100 mA Max
Source and sink current	50 mA for channel 20 mA for channel with LINE DRIVER
Output types	NPN / NPN OPEN COLLECTOR / PUSH PULL / LINE DRIVER
Output frequency	100 KHz Max
Frequency response	$F = \frac{\text{RPM} \times \text{Resolution}}{60}$

Mechanical specifications

Shaft diameter	ø6 mm g6
Enclosure rating	IP54 standard
Shaft speed	3000 RPM
Max shaft load	5N (0.5 Kp) axial 5N (0.5 Kp) radial
Shock	50 G for 11 msec
Vibrations	10G 10 ÷ 2000 Hz
Bearings life	10 ⁹ revolutions
Bearings	n° 2 Ball bearings
Shaft material	Stainless steel AISI303
Body material	Aluminium UNI 5076
Flange material	Aluminium
Housing material	PA 66 reinforced with fiber glass
Operating temperature	0° ÷ +60°C
Storage temperature	-25° ÷ +70°C
Weight	100 g

EL 40 A

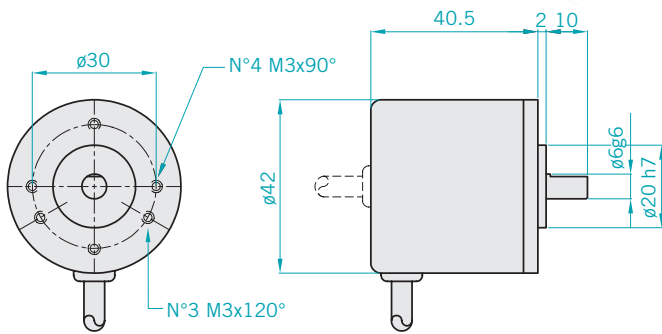

EL 40 B

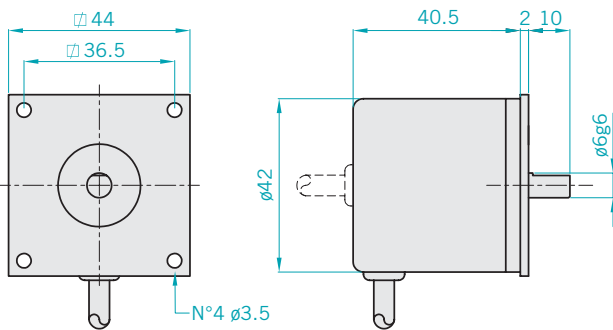

EL 40 C/E

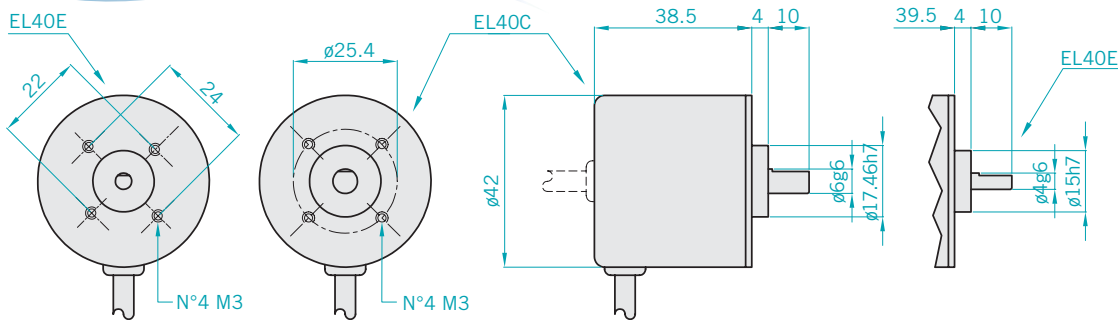

EL 40 H/I

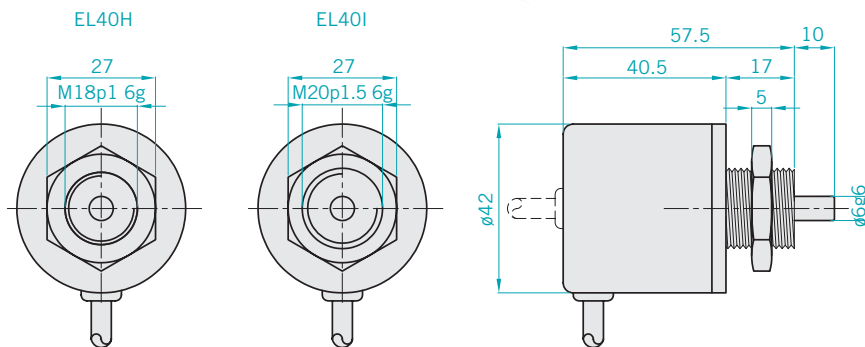

Electrical specifications

Resolution	From 1 to 2000 PPR
Input voltage	5 ÷ 28 Vdc LINE DRIVER only available with input voltage 5 / 8÷24
Input current with no output load	100 mA max
Source and sink current	50 mA for channel 20 mA for channel with LINE DRIVER
Output types	NPN / NPN OPEN COLLECTOR / PUSH PULL / LINE DRIVER
Frequency response	100 KHz MAX (EL) $F = \frac{\text{RPM} \times \text{Resolution}}{60}$

Mechanical specifications

Shaft diameter	$\phi 4$ mm g6 EL40 E $\phi 6$ mm g6 EL40 A/B/C/H/I
Enclosure rating	IP54 standard EL40 C/E/H/I IP65 standard EL40 A/B IP66 standard EL40 A/B (only axial output with skintop)
Shaft speed	3000 RPM 6000 RPM
Max shaft load	5N (0.5 Kp) axial 5N (0.5 Kp) radial
Shock	50 G for 11 msec
Vibrations	10G 10 ÷ 2000 Hz
Bearings life	10^9 revolu-
Bearings	n° 2 Ball bearings
Shaft material	Stainless steel AISI303
Body material	Aluminium D11S - UNI 9002/5
Housing material	PA 66 reinforced with fiber glass
Operating temperature	0° ÷ +60°C
Storage temperature	-25° ÷ +70°C
Weight	100 g



EH-EL 58 B/C/H/T INCREMENTAL ENCODER



Incremental encoder

Standard encoder Ø58 series for industrial applications with high mechanical resistance requirements. Those encoders are designed to support high radial and axial shaft load and they can be mounted with flanges or servo-fasteners.

- Up to 10.000 ppr with zero for EL series, up to 1024 ppr for EH series.
- Several output types available.
- Up to 28 Vdc input voltage for EL series and up to 24 Vdc for EH series.
- Up to 300 kHz frequency response for EL series and up to 100 kHz for EH series
- Output cable with connector.
- Several flanges available
- Up to 6.000 rpm speed rotation
- Up to IP66 sealing



shaft INCREMENTAL ENCODERS

Ordering code

Full stop to separate special versions

EL 58 B 1000 Z 5/28 P 6 X 6 P R . XXX

<p>incremental encoder series EL</p> <p>incremental encoder series EH</p> <p>body dimension 58</p> <p>Type of flange</p> <p>mod.EH-EL 58 B</p> <p>mod.EH-EL 58 C</p> <p>mod.EH-EL 58 H</p> <p>mod.EH-EL 58 T</p> <p>Resolution</p> <p>From 1 to 10000 PPR for series EL</p> <p>From 40 to 1024 PPR for series EH</p> <p><i>Please, directly contact our offices for pulses availability</i></p> <p>Zero pulse</p> <p>without zero pulse S</p> <p>with zero pulse Z</p> <p>Input voltage</p> <p>input voltage EL 5 ÷ 28</p> <p>input voltage EH 5/8 ÷ 24</p> <p><i>LINE DRIVER available only with input voltage 5 Vdc or 8 ÷ 24 Vdc</i></p>	<p>6 X 6 P R . XXX</p> <p>R.P.M.</p> <p>3 3000</p> <p>6 6000</p> <p><i>Enclosure rating S 3000 turn</i></p> <p>Enclosure rating</p> <p>X standard IP54</p> <p>S optional IP66</p> <p>Shaft diameter</p> <p>6 ø 6 g6 mm EH-EL58 B/C/H</p> <p>8 ø 8 g6 mm EH-EL58 B/C/H/T</p> <p>9 ø 9,52 g6 mm (3/8") EH-EL58 B/C/H</p> <p>10 ø 10 g6 mm EH-EL58 B/C/H/T</p> <p>12 ø 12 g6 mm EH-EL58 T</p> <p>Output types</p> <p>N NPN</p> <p>C NPN OPEN COLLECTOR</p> <p>P PUSH PULL</p> <p>L LINE DRIVER (only series EL)</p> <p><i>For optionals about output types please refer to incremental output section</i></p>	<p>Special version code numbered from 001 to 999</p> <p>R radial</p> <p>A axial</p> <p>P cable output (standard length 1,5 m)</p> <p>M connector MS3106E 16S-1S o 18-1S</p> <p>J connector JMSP 1607 F o 1610 F</p>
--	---	---

EH-EL58 B/C/H/T

EH-EL 58 B

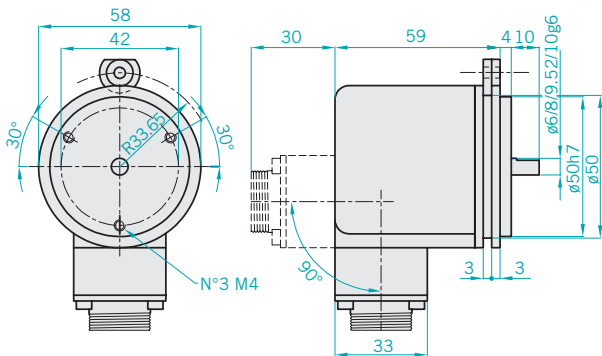

EH-EL 58 C

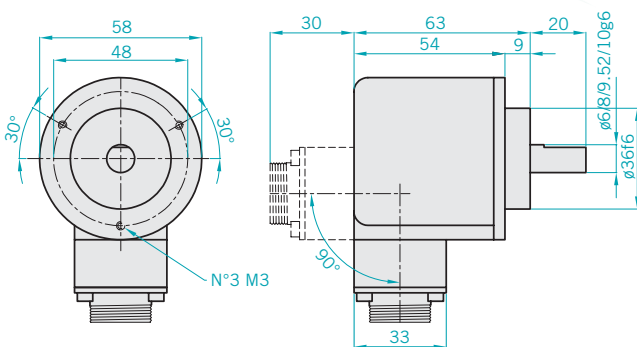

EH-EL 58 H

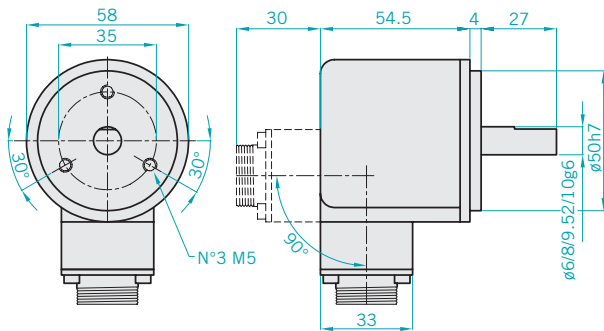

EH-EL 58 T

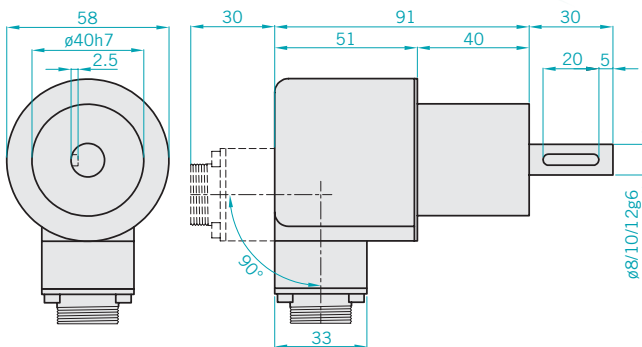

EL series electrical specifications

Resolution	From 1 to 10000 PPR
Input voltage	5 ÷ 28 Vdc LINE DRIVER only available with input voltage 5 / 8÷24 Vdc
Input current with no output load	100 mA Max
Source and sink current	50 mA for channel 20 mA for channel with LINE DRIVER
Output types	NPN / NPN OPEN COLLECTOR / PUSH PULL / LINE DRIVER
Frequency response	300 KHz Max $F = \frac{RPM \times Resolution}{60}$

EH series electrical specifications

Resolution	From 40 to 1024 PPR
Input voltage	5 Vdc / 8 ÷ 24 Vdc
Input current with no output load	100 mA Max
Source and sink current	50 mA for channel 20 mA for channel with LINE DRIVER
Output types	NPN / NPN OPEN COLLECTOR / PUSH PULL / LINE DRIVER
Frequency response	100 KHz Max $F = \frac{RPM \times Resolution}{60}$

Mechanical specifications

Shaft diameter	6/8/9,52 (3/8")/10 mm g6 EH- EL58 B/C/H
Enclosure rating	IP54 standard IP66
Shaft speed	3000 RPM 6000 RPM 3000 RPM MAX with "S" rating
Max shaft load	200N (20 Kp) axial 10N (1 Kp) axial 200N (20 Kp) radial 20N (2 Kp) radial with shaft 6 mm
Shock	50 G for 11 msec (with plastic disc) 20 G for 11 msec (with glass disc)
Vibrations	10G 10 ÷ 2000 Hz
Bearings life	10 ⁹ revolutions
Bearings	n° 2 Ball bearings
Shaft material	Stainless steel AISI303
Body material	Aluminium D11S - UNI 9002/5
Housing material	PA 66 reinforced with fiber glass
Operating temperature	0° ÷ +60°C
Storage temperature	-25° ÷ +70°C
Weight	300 g



EH-EL 63 A/D/E INCREMENTAL ENCODER



Incremental encoder

- Standard encoder Ø63 series for industrial applications with high mechanical resistance requirements. Those encoders are designed to support high radial and axial shaft load and they can be mounted with flanges or servo-fasteners.
- Up to 10.000 ppr with zero for EL series, up to 1024 ppr for EH series.
 - Several output types available.
 - Up to 28 Vdc input voltage for EL series and up to 24 Vdc for EH series.
 - Up to 300 kHz frequency response for EL series and up to 100 kHz for EH series
 - Output cable with connector.
 - Several flanges available
 - Up to 6.000 rpm speed rotation
 - Up to IP66 sealing



shaft INCREMENTAL ENCODERS

Ordering code

Full stop to separate special versions

EL 63 A 1000 Z 5/28 P 6 X 6 M R . XXX

incremental encoder series EL	incremental encoder series EH	body dimension 63	Type of flange mod.EH-EL 63 A A mod.EH-EL 63 D D mod.EH-EL 63 E E	Resolution 1 to 10000 PPR for series EL 40 to 1024 PPR for series EH <i>Please, directly contact our offices for pulses availability</i>	Zero pulse without zero pulse S with zero pulse Z	Input voltage input voltage EL 5 ÷ 28 input voltage EH 5 / 8 ÷ 24 <i>LINE DRIVER available only with input voltage 5 Vdc or 8 ÷ 24 Vdc</i>	Special version code numbered from 001 to 999
							R radial A axial
							P cable output (standard length 1,5 m) M connector MS3106E 16S-1S or 18-1S J connector JMSP 1607 F or 1610 F
							R.P.M. 3 3000 6 6000 <i>Enclosure rating "S" 3000 RPM</i>
							Enclosure rating X standard IP54 S optional IP66
							Shaft diameter 8 ø 8 mm 9 ø 9,52 mm (3/8") 10 ø 10 mm
							Output types N NPN C NPN OPEN COLLECTOR P PUSH PULL L LINE DRIVER <i>For optionals about output types please refer to incremental output section</i>

EH-EL63 A/D/E

EH-EL 63 A

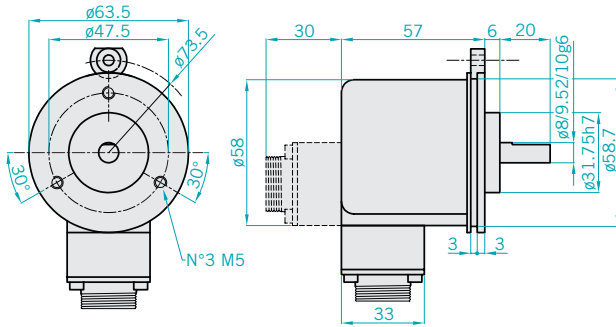

EH-EL 63 D

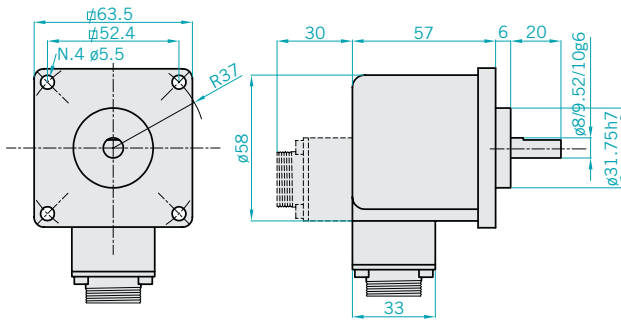

EH-EL 63 E

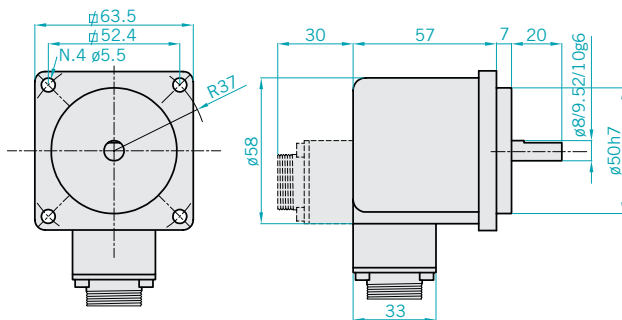

EL electrical specifications

Resolution	From 1 to 10000 PPR
Input voltage	5 ÷ 28 Vdc LINE DRIVER only available with input voltage 5 / 8÷24 Vdc
Input current with no output load	100 mA Max
Source and sink current	50 mA for channel 20 mA for channel with LINE DRIVER
Output types	NPN / NPN OPEN COLLECTOR / PUSH PULL / LINE DRIVER
Frequency response	300 KHz Max $F = \frac{RPM \times Resolution}{60}$

EH electrical specifications

Resolution	From 40 to 1024 PPR
Input voltage	5 Vdc / 8 ÷ 24 Vdc
Input current with no output load	100 mA Max
Source and sink current	50 mA for channel 20 mA for channel with LINE DRIVER
Output types	NPN / NPN OPEN COLLECTOR / PUSH PULL / LINE DRIVER
Frequency response	100 KHz Max $F = \frac{RPM \times Resolution}{60}$

Mechanical specifications

Shaft diameter	$\phi 6 - \phi 9.52$ (3/8") - $\phi 10$ mm g6
Enclosure rating	IP54 standard IP66
Shaft speed	3000 RPM 6000 RPM Enclosure rating "S" 3000 RPM
Shock	50 G for 11 msec (with plastic disc) 20 G for 11 msec (with glass disc)
Vibrations	10G 10 ÷ 2000 Hz
Bearings life	10^9 revolutions
Bearings	n° 2 Ball bearings
Shaft material	Stainless steel AISI303
Body material	Aluminium UNI 5076
Housing material	PA 66 reinforced with fiber glass
Operating temperature	0° ÷ +60°C
Storage temperature	-25° ÷ +70°C
Weight	350 g



EH-EL90A/115 A-R INCREMENTAL ENCODER



Incremental encoder

Encoder series for critical environments with high mechanical resistance requirements. The 90 model can be mounted with flanges or servo-fasteners; the 115 model has a tachometer generator type REO-444 compatible plug.

- Up to 10.000 ppr with zero for EL series, up to 1024 ppr for EH series.
- Several output types available.
Up to 28 Vdc input voltage for EL series and up to 24 Vdc for EH series.
- Up to 300 kHz frequency response for EL series and up to 100 kHz for EH series
- Output cable with connector.
- Several flanges available
- Up to 6.000 rpm speed rotation
- Up to IP66 sealing model 90A



shaft INCREMENTAL ENCODERS

Ordering code

Full stop to separate special versions

EL 90 A 1000 Z 5/28 N 1000 Z 5/28 N 8 X 6 M R . XXX

incremental encoder series **EL**
 incremental encoder series **EH**
 body dimension **90**
 body dimension **115**
Type of flange
 mod.EH-EL 90A / 115A **A**
 only mod.EH / EL115R **R**

R radial
A axial
P cable output (standard length 1,5 m)
M connector MS3106E 16S-1S or 18-1S
J connector JMS1607 F or 1610 F

Special version code numbered from 001 to 999

Resolution

from **1** to **10000** PPR for series EL
 from **40** to **1024** PPR for series EH
Please, directly contact our offices for pulses availability

Zero pulse

without zero pulse **S**
 with zero pulse **Z**

Input voltage

input voltage EL **5 ÷ 28**
 input voltage EH **5 / 8 ÷ 24**
LINE DRIVER available only with input voltage 5 Vdc or 8 ÷ 24 Vdc

Output types

NPN **N**
 NPN OPEN COLLECTOR **C**
 PUSH PULL **P**
 LINE DRIVER **L**

For options about output types please refer to incremental output section

R.P.M.

3 3000
6 6000

Enclosure rating S 3000 turn

Enclosure rating

X standard IP54
S optional IP66 for mod 90 A

Shaft diameter

8 ø 8 g6 mm EH-EL90
9 ø 9,52 g6 mm (3/8") EH-EL90
10 ø 10 g6 mm EH-EL90 / 115
11 ø 11 g6 mm EH-EL115

Output types

Input voltage

Zero pulse

Resolution

To be indicated only on models with double electronics for more information please contact our offices)

EH-EL 90A/115 A-R

EH-EL 90 A

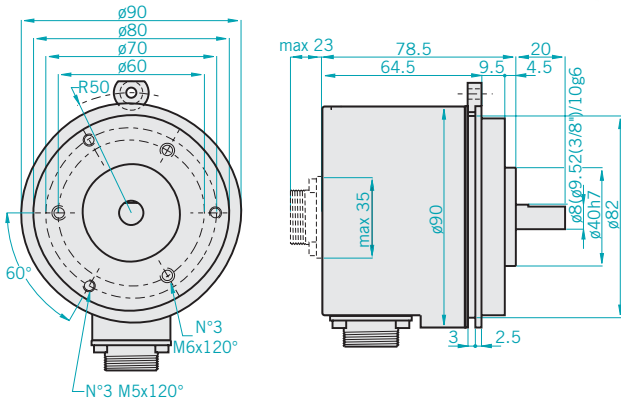

EH-EL 115 A

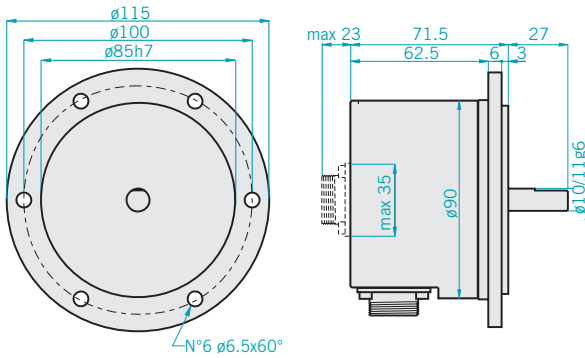

EH-EL 90 A/115 A with double electronic

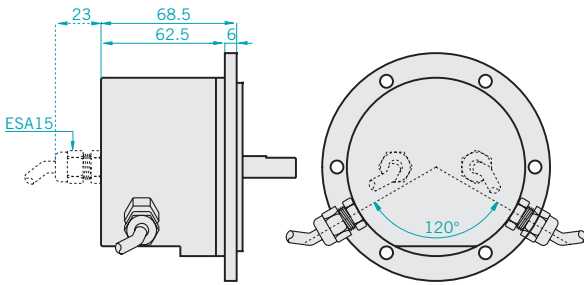

EH-EL 115 R with centrifugal relè

Overall dimension for EH/EL115 R

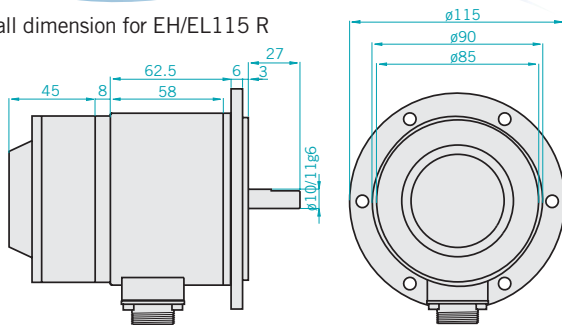

EL series electrical specifications

Resolution	From 1 to 10000 PPR
Input voltage	5 ÷ 28 Vdc LINE DRIVER only available with input voltage 5 / 8÷24 Vdc
Input current with no output load	100 mA Max
Source and sink current	50 mA for channel 20 mA for channel LINE DRIVER
Output types	NPN / NPN OPEN COLLECTOR / PUSH PULL / LINE DRIVER
Frequency response	300 KHz Max $F = \frac{RPM \times Resolution}{60}$

EH series electrical specifications

Resolution	From 40 to 1024 PPR
Input voltage	5 Vdc / 8 ÷ 24 Vdc
Input current with no output load	100 mA Max
Source and sink current	50 mA for channel 20 mA for channel LINE DRIVER
Output types	NPN / NPN OPEN COLLECTOR / PUSH PULL / LINE DRIVER
Frequency response	100 KHz Max $F = \frac{RPM \times Resolution}{60}$

Mechanical specifications

Shaft diameter	ø8 / ø9,52 (3/8") / ø10 mm g6 ø10 / ø11 mm g6	EH-EL90 EH-EL115
Enclosure rating	IP54 standard IP66 optional mod. 90 A	
Shaft speed	3000 RPM 6000 RPM 3000 RPM MAX with "S" rating	
Max shaft load	200N (20 Kp) axial 200N (20 Kp) radial	
Shock	50 G for 11 msec (with plastic disc) 20 G for 11 msec (with glass disc)	
Vibrations	10G 10 ÷ 2000 Hz	
Bearings life	10 ⁹ revolu-	
Bearings	n° 2 Ball bearings	
Shaft material	Stainless steel AISI303	
Body material	Aluminium D11S - UNI	
Housing material	Painted aluminium	
Operating temperature	0° ÷ +60°C	
Storage temperature	-25° ÷ +70°C	
Weight	750 g	



EF 36 K INCREMENTAL ENCODER + INCREMENTAL PHASES



Incremental encoders for motor feedback

Ø36 encoder series used in feedback systems on AC servomotor. It integrates a traditional incremental encoder and the optical generation of "Hall effect phases".

Main characteristics are:

- Interchangeability with 15 size resolver that allow to save time and money because it is sufficient to have only one predisposition for the retromotor.
- Easy mechanical assembly
- Contained dimensions
- Wide resolution range available



hollow shaft INCREMENTAL ENCODERS

Signal configuration

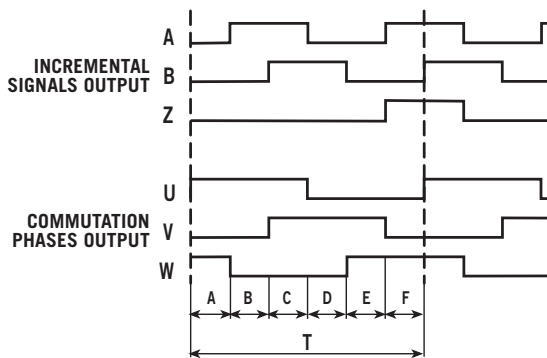

POLES	A/B/C/D/E/F	T
4	30° ± 1.5°	180°
6	20° ± 1.5°	120°
8	15° ± 1.5°	90°

Electrical specifications

Resolution	from 1 to 1024 PPR
Source and sink current	15 mA for channel with LINE DRIVER 30 mA for channel with other electronics
Frequency response	150 KHz Max $F = \frac{RPM \times Resolution}{60}$

EF series electrical specifications

Input voltage	5Vdc ± 5%
Output type for incremental signal	LINE DRIVER
Output types for Hall phases	LINE DRIVER/ NPN OPEN COLLECTOR
Input current with no output load	150 mA

Mechanical specifications

Bore diameter	ø8 / ø9.52 / ø10 mm H7
Enclosure rating	IP40
Shaft speed	6000 RPM
Shock	50 G for 11 msec
Vibrations	5G 10 ÷ 500 Hz
Bearings	n° 2 ball bearings
Shaft material	Stainless steel
Body material	Aluminium
Housing material	Aluminium
Operating temperature	-10° ÷ +85°C
Storage temperature	-25° ÷ +85°C
Weight	50 g
Accessories	Flange for mounting on motors (size 15 "Resolver")

Wire colours

COLOUR	SIGNAL	EF
Red	+ Vdc	•
Black	0 Volt	•
Green	A	•
Yellow	B	•
Blue	Z	•
Brown	\bar{A}	•
Orange	\bar{B}	•
White	\bar{Z}	•
Gray	U	•
Violet	V	•
Gray/Pink	W	•
Red / Blue	\bar{U}	•
White/Green	\bar{V}	•
Brown / Green	\bar{W}	•

EF 36 K



EL 38 F / G INCREMENTAL ENCODER



Incremental encoder

Miniaturised Ø38 encoder series. Used when a minimal size is required even providing excellent performances.

- Resolution up to 2.000 ppr with zero.
- Several electronic output configurations available.
- Up to 28 Vdc input voltage.
- Up to 100 kHz frequency response
- Several flanges available
- Up to 3.000 rpm speed rotation
- Up to IP54 sealing



hollow shaft INCREMENTAL ENCODERS

Ordering code

EL	38	F	500	Z	5/28	N	6	X	3	P	R	.	XXX
Incremental encoder series EL	Body dimension 38	Type of flanges mod.EL 38 F F mod.EL 38 G G	Resolutions from 1 to 2000 PPR <i>Please, directly contact our offices for pulses availability</i>	Zero pulse without zero pulse S with zero pulse Z	Input voltage Input voltage 5 ÷ 28 <i>LINE DRIVER available only with input voltage 5 Vdc 8 ÷ 24 Vdc</i>	Full stop to separate special versions.	R.P.M. 3 3000	Enclosure rating X standard IP54	Bore diameter 6 ø 6 g6 mm 8 ø 8 g6 mm 9 ø 9,52 g6 mm (3/8") 10 ø 10 g6 mm	Output types N NPN C NPN OPEN COLLECTOR P PUSH PULL L LINE DRIVER <i>For optionals about output types please refer to incremental outputs section</i>	R radial	P cable output (standard length 0.5 m)	Special version code numbered from 001 to 999

EL38 F / G

EL 38 F

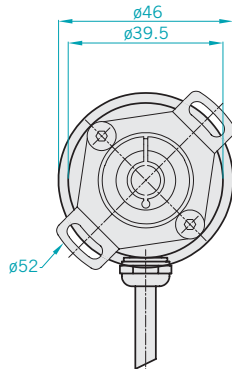
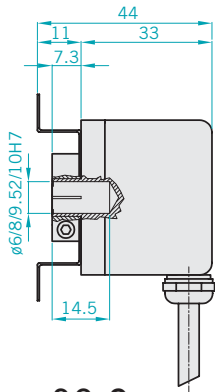

EL 38 G

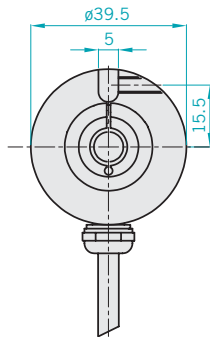
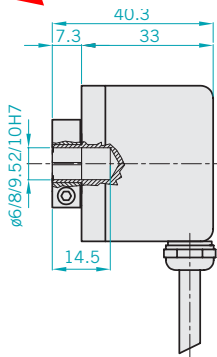

EL 38 F

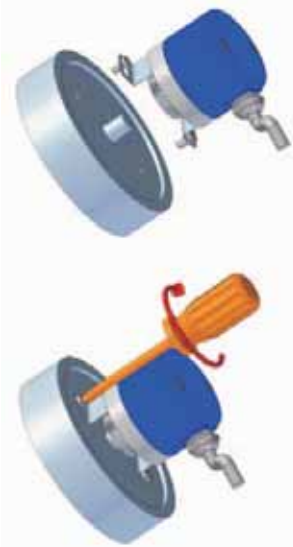

EL 38 G



HOW TO MOUNT IT

- 1) Couple the encoder shaft with the motor shaft
- 2) Fix the spring at the motor flanges without screwing it
- 3) Fix the encoder shaft by the metal ring
- 4) Block the spring

HOW TO MOUNT IT

- 1) Mount the antirotation pin on the motor flange.
- 2) Couple the encoder shaft with the motor shaft, ensuring that the pin is inserted on the cave on the frontal part of the encoder (maintaining a minimum distance of 0,5 mm)
- 3) Fix the encoder shaft by the metal ring

Electrical specifications

Resolution	from 1 to 2000 PPR
Input voltage	5 \pm 28 Vdc LINE DRIVER available only with input voltage 5 / 8-24 Vdc
Input current with no output load	80 mA MAX
Source and sink current	50 mA for channel 20 mA for channel with LINE DRIVER
Output types	NPN / NPNOPEN COLLECTOR / PUSH PULL / LINE DRIVER
Output frequency	100 KHz Max
Frequency response	$F = \frac{RPM \times Resolution}{60}$

Mechanical specifications

Bore diameter	$\varnothing 6 - \varnothing 8 - \varnothing 9.52 (3/8") - \varnothing 10$ mm
Enclosure rating	IP54 standard
Shaft speed	3000 RPM
Max shaft load	5N (0.5 Kp) axial 5N (0.5 Kp) radial
Shock	50 G for 11 msec
Vibrations	10G 10 \div 2000 Hz
Vita Bearings	10 ⁹ revolu-
Bearings	n° 2 ball bearings
Shaft material	Stainless steel AISI303
Body material	Aluminium D11S - UNI 9002/5
Housing material	Fe
Operating temperature	0° \div +60°C
Storage temperature	-25° \div +70°C
Weight	150 g



EL40 G/GR INCREMENTAL ENCODER



Incremental encoder

- Miniaturised encoder Ø42 series for general applications.
- Up to 2.000 ppr with zero for EL series
- Different output types available.
- Up to 28 Vdc input voltage.
- Up to 100 kHz frequency response
- Output cable. Cable connector available on request.
- Several flanges available
- Up to 3.000 rpm speed rotation
- IP54 sealing



hollow shaft INCREMENTAL ENCODERS

Ordering code

Full stop to separate special versions.

EL 40 G 1000 Z 5/28 P 6 X 3 P R . XXX

<p>Incremental encoder series EL</p> <p>Body dimension 40</p> <p>Type of flanges mod. EL40 G G mod. EL40 GR GR</p> <p>Resolutions from 1 to 2000 PPR series EL <i>Please, directly contact our offices for pulses availability</i></p> <p>Zero pulse without zero pulse S with zero pulse Z</p> <p>Input voltage input voltage EL 5 ÷ 28 <i>LINE DRIVER available only with input voltage 5 Vdc 8 ÷ 24 Vdc</i></p>	<p>R.P.M. 3 3000</p> <p>Enclosure rating X standard IP54</p> <p>Bore diameter</p> <table border="0"> <tr> <td>6</td> <td>ø 6 H 7 mm</td> <td>EL40 G/GR (hole)</td> </tr> <tr> <td>8</td> <td>ø 8 H 7 mm</td> <td>only EL40 GR</td> </tr> <tr> <td>9</td> <td>ø 9.52 H 7 mm</td> <td>only EL40 GR</td> </tr> <tr> <td>10</td> <td>ø 10 H 7 mm</td> <td>only EL40 GR</td> </tr> </table> <p>Output types</p> <p>N NPN C NPN OPEN COLLECTOR P PUSH PULL L LINE DRIVER <i>For optionals about output types please refer to incremental outputs section</i></p>	6	ø 6 H 7 mm	EL40 G/GR (hole)	8	ø 8 H 7 mm	only EL40 GR	9	ø 9.52 H 7 mm	only EL40 GR	10	ø 10 H 7 mm	only EL40 GR	<p>R radial A axial</p> <p>P cable output (standard length 0.5 m)</p> <p>XXX Special version code numbered from 001 to 999</p>
6	ø 6 H 7 mm	EL40 G/GR (hole)												
8	ø 8 H 7 mm	only EL40 GR												
9	ø 9.52 H 7 mm	only EL40 GR												
10	ø 10 H 7 mm	only EL40 GR												

EL40 G/GR

EL 40 G

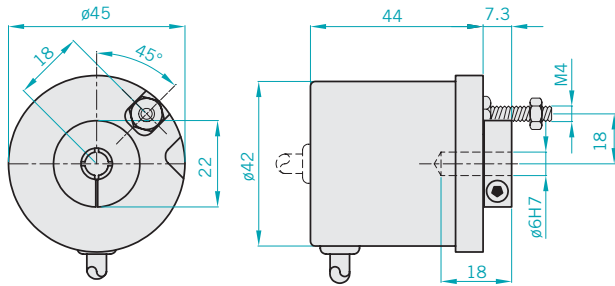

EL 40 GR

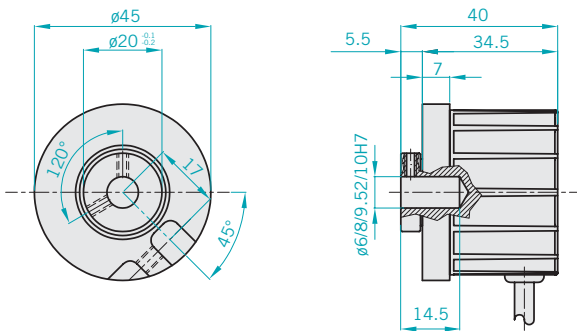

HOW TO MOUNT IT

- 1) Fix the antirotation pin on the motor flange
- 2) Couple the encoder shaft with the motor shaft, ensuring that the pin is inserted on the cave on the frontal part of the encoder (maintaining a minimum distance of 0,5 mm)
- 3) Fix the encoder shaft by the metal ring

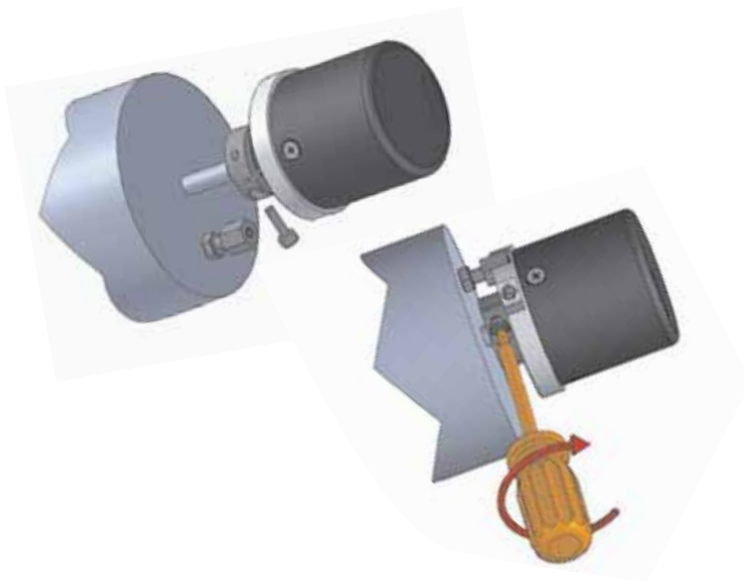

Electrical specifications

Resolution	from 1 to 2000 PPR
Input voltage	5 \pm 28 Vdc LINE DRIVER available only with input voltage 5 / 8-24 Vdc
Input current with no output load	100 mA Max
Source and sink current	50 mA for channel 20 mA for channel LINE DRIVER
Output types	NPN / NPN OPEN COLLECTOR / PUSH PULL / LINE DRIVER
Frequency response	100 KHz Max $F = \frac{\text{RPM} \times \text{Resolution}}{60}$

Mechanical specifications

Bore diameter	$\phi 6h7$ mm EL40 G/GR $\phi 8/9.52/10$ h7 EL40 GR
Enclosure rating	IP54 standard
Shaft speed	3000 RPM
Max shaft load	5N (0.5 Kp) axial 5N (0.5 Kp) radial
Shock	50 G for 11 msec
Vibrations	10G 10 \div 2000 Hz
Bearings life	10 ⁹ revolu-
Bearings	n° 2 ball bearings
Shaft material	Stainless steel AISI303
Body material	Aluminium D11S - UNI 9002/5
Housing material	PA 66 reinforced with fiber glass
Operating temperature	0° \div +60°C
Storage temperature	-25° \div +70°C
Weight	150 g



EL/EF/EW48C-P INCREMENTAL ENCODER + COMMUTATION PHASES



Encoder series EL/EF/EW48 C-P

Ø48 encoder series used in feedback systems on AC servomotor. They integrate a traditional incremental encoder with the optic generation of "Hall effect phases".
Main characteristics are::

- Easy mechanical assembly
- Contained dimensions
- Wide resolution range available
- High temperature resistance

EL series

Basic version with incremental outputs
Several output types available

EF series

Optic engendering of the "commutation phases" integrated to the basic version
Signals transmission by parallel connection

EW series

Special version of the EF series featuring a wiring simplification, obtained through the sequential transmission of the incremental and commutation phases as shown on the below graph.

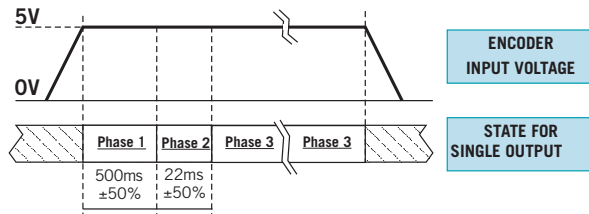

- Phase 1** HIGH "HZ" IMPEDANCE PHASE
- Phase 2** TRANSMISSION COMMUTATION PHASES
- Phase 3** INCREMENTAL OUTPUT SIGNAL TRANSMISSION

Signal configuration

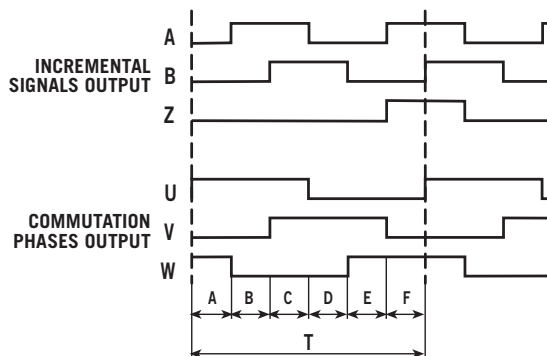

POLES	A/B/C/D/E/F	T
4	30° ± 1.5°	180°
6	20° ± 1.5°	120°
8	15° ± 1.5°	90°



Electrical specifications

Resolution from 1 to 2048 PPR

Source and sink current 15 mA for channel with LINE DRIVER
30 mA for channel with other electronics

Frequency response 150 KHz Max
 $F = \frac{\text{RPM} \times \text{Resolution}}{60}$

EL series electrical specifications

Input voltage 5Vdc / 8÷24 Vdc

Output type NPN / NPN OPEN COLLECTOR / PUSH PULL / LINE DRIVER

Input current with no output load 100 mA Max

EF/EW series electrical specifications

Input voltage 5Vdc ± 5%

Output types for incremental phases LINE DRIVER

Output types for Hall phases LINE DRIVER / NPN OPEN COLLECTOR

Input current with no output load 150 mA Max

Wire colours

COLOUR	SIGNAL	EL	EF	EW
Red	+ Vdc	•	•	•
Black	0 Volt	•	•	•
Green	A	•	•	•
Yellow	B	•	•	•
Blue	Z	•	•	•
Brown	A̅	•	•	•
Orange	B̅	•	•	•
White	Z̅	•	•	•
Gray	U		•	
Violet	V		•	
Gray/Pink	W		•	
Red / Blue	U̅		•	
White/Green	V̅		•	
Brown / Green	W̅		•	

EL/EF/EW 48 mod. C-P

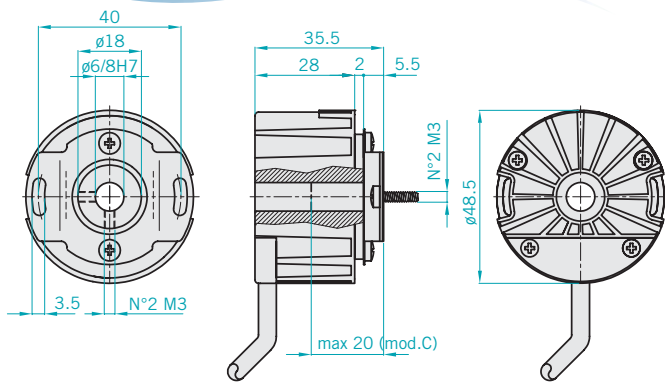

HOW TO MOUNT IT

- 1) Couple the encoder shaft with the motor shaft
- 2) Fix the spring at the motor flanges without screwing it
- 3) Fix with the two grains the encoder shaft
- 4) Turn for phasing
- 5) Block the spring



Mechanical specifications

Bore diameter	ø6 / ø8 mm H7
Enclosure rating	IP40
Shaft speed	6000 RPM
Shock	50 G for 11 msec
Vibrations	10G 10 ÷ 500 Hz
Bearings	n° 2 ball bearings
Shaft material	Brass OT58 UNI 5705-65
Body material	Aluminium D11S - UNI 9002/5
Housing material	PA 66 reinforced with fiber glass
Operating temperature	-10° ÷ +85°C
Storage temperature	-25° ÷ +85°C
Weight	100 g

Ordering code

Full stop to separate special versions.

EF 48 C 6 L 2000 Z 5 L 6 X 6 PR . XXX

Incremental encoder **EL**
 Incremental encoder + commutation phases **EH**
 version "LESS WIRED" transmission with less wire **EW**

Body dimension **48**
 blind hole **C**
 hollow shaft **P**

N° poles of the motor
 n° 4 poles **4**
 n° 6 poles **6**
 n° 8 poles **8**

Electronic for commutation phase
 NPN OPEN COLLECTOR **C**
 LINE DRIVER **L**
indicates only with models EF/EW

Incremental encoder resolution
1 to 2048 PPR
Please, directly contact our offices for pulses availability

Zero pulse
 without zero pulse **S**
 with zero pulse **Z**

Special version code numbered from 001 to 999

PR cable output radial (standard length 0.3 m)

6 6000 R.P.M. max

X Enclosure rating IP40

Bore diameter
6 ø 6 mm
8 ø 8 mm

Electronics for mod. EF/EW
L LINE DRIVER

Electronics for mod. EL
N NPN
C NPN OPEN COLLECTOR
P PUSH PULL
L LINE DRIVER

Input voltage for mod. EF/EW
5 Vdc

Input voltage for mod. EL
5 Vdc
8 ÷ 24 from 8 to 24Vdc



EL/EF49C-P

INCREMENTAL ENCODER/
INCREMENTAL ENCODER+
COMMUTATION PHASES



Motor's line Incremental encoder

Ø49 encoder series used in feedback systems on AC servomotor. They integrate a traditional incremental encoder with the optic generation of "Hall effect phases".
Main characteristics are:

- Interchangeability with size 19 resolver representing a cost-effective solution because it is sufficient to have only one predisposition on the motor.
- Wiring simplification using the connector kit
- Contained dimensions
- Wide resolution range available
- High temperature resistance

EL series

Basic version with incremental outputs
Several output types available

EF series

Optic engendering of the "commutation phases" integrated to the basic version
Signals transmission by parallel connection

Electrical specifications

Resolution from 1 to 2048

Source and sink current 15 mA for channel with LINE DRIVER
30 mA for channel with other electronics

Frequency response 150 KHz Max
 $F = \frac{RPM \times Resolution}{60}$

EL series electrical specifications

Input voltage 5Vdc / 8÷24 Vdc

Output type NPN / NPN OPEN COLLECTOR /
PUSH PULL / LINE DRIVER

Input current with no output load 100 mA Max

EF series electrical specifications

Input voltage 5Vdc ± 5%

Output types for incremental phases LINE DRIVER

Output types for Hall phases LINE DRIVER/
NPN OPEN COLLECTOR

Input current with no output load 150 mA Max

Mechanical specifications

Bore diameter Ø6 / Ø8 / Ø10 / Ø12 / Ø12.7 (1/2") mm H7

Shaft speed 6000 RPM

Shock 50 G for 11 msec

Vibrations 5G 10 ÷ 500 Hz

Bearings n° 2 ball bearings

Shaft material Stainless steel
Body material Aluminium
Housing material Fe

Weight 100 g

Enclosure rating IP40

Operating temperature -10° + 85°C

Storage temperature -25° + 85°C

Accessories

- 1) Set n° 3 fasteners
Ordering code: 94080001
- 2) Flanges for fixing on motors with "Resolver" size 19 versions 01 and 14

Signal configuration

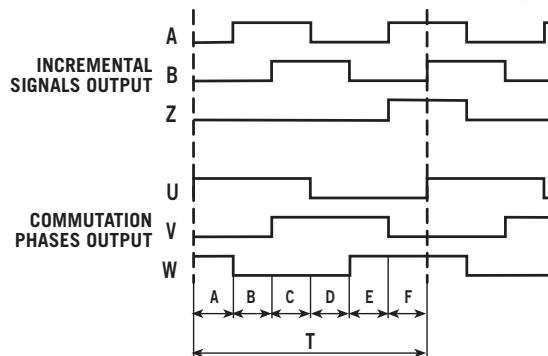

POLES	A/B/C/D/E/F	T
4	30° ± 1.5°	180°
6	20° ± 1.5°	120°
8	15° ± 1.5°	90°

Wire colours

COLOUR	SIGNAL	EL	EF
Red	+ Vdc	•	•
Black	0 Volt	•	•
Green	A	•	•
Yellow	B	•	•
Blue	Z	•	•
Brown	Ā	•	•
Orange	B̄	•	•
White	Z̄	•	•
Gray	U	•	•
Violet	V	•	•
Gray/Pink	W	•	•
Red / Blue	Ū	•	•
White/Green	V̄	•	•
Brown / Green	W̄	•	•

EL/EF 49 C-P

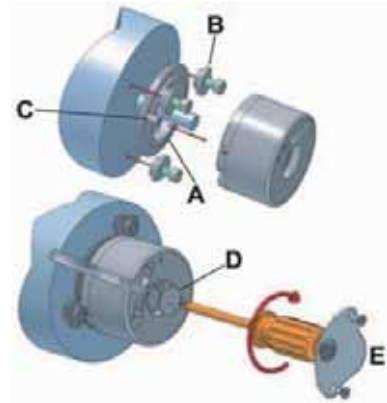
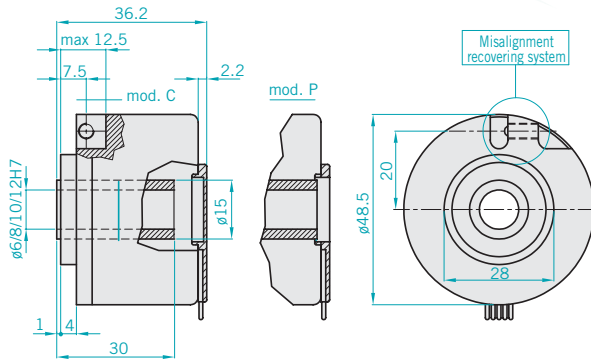

Accessories

Flanges for fixing on motors

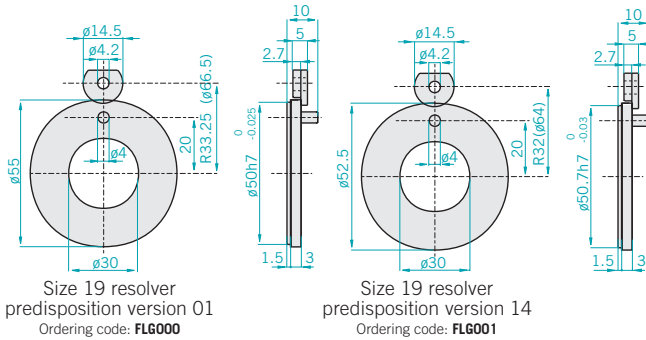

Size 19 resolver
predisposition version 01
Ordering code: **FL6000**

Size 19 resolver
predisposition version 14
Ordering code: **FL6001**

HOW TO MOUNT IT

- 1) Insert the flange (A) on the motor
- 2) Tighten the appropriate servo fasteners (B) blocking them
- 3) Insert the encoder on the motor shaft with the system of misalignment recuperation corresponding to the pegs (C)
- 4) Insert the washer on the rear and block it using the encoder screw on the motor axle
- 5) Turn for phasing
- 6) As final step, fix the servo-fasteners (B).
Check if the misalignment recovery system works correctly
- 7) Verify the correct functioning of the disalignment recovery system.
Check if the misalignment recovery system works correctly
- 8) Insert the connector (E) and place the plastic lid (F) corresponding to the holes and then screw them.

Ordering code

Full stop to separate special versions.

EF 49 C 6 L 2000 Z 5 L 8 X 3 LR . XXX

Incremental encoder Incremental encoder + commutation phases	EL EF	Special version code numbered from 001 to 999
Body dimension	49	LR radial output cable 0,3 m long
blind hole	C	MA radial output cable 0,2 m with M19 poles type cconnector
Hollow shaft	P	R.P.M. 6 6000 max
N° poles of the motor	n° 4 poles 4 n° 6 poles 6 n° 8 poles 8	Enclosure rating X IP40
Electronic for commutation phase	NPN OPEN COLLECTAR C LINE DRIVER L <small>indicates only with models EF</small>	Bore diameter 6 $\phi 6H7$ mm 8 $\phi 8H7$ mm 10 $\phi 10H7$ mm 12 $\phi 12H7$ mm 12,7 $\phi 12.7 (1/2")H7$ mm
Incremental encoder resolution from 1 to 2048 PPR <small>Please, directly contact our offices for pulses availability</small>		Electronics for mod. EL N NPN C NPN OPEN COLLECTOR P PUSH PULL L LINE DRIVER
Zero pulse without zero pulse S with zero pulse Z		Electronics for mod. EF L LINE DRIVER <small>For optionals about output types please refer to incremental outputs section</small>
Input voltage mod. EF 5 Vdc 5		
Input voltage mod. EL 5 Vdc 5 from 8 to 24Vdc 8 ÷ 24		





EL50 F/G/K INCREMENTAL ENCODER



Incremental encoder

- Ø50 encoder series used on motor feedback.
- Several way to fix it
- Easy mechanical installation
- Contained dimensions
- Up to 2.048 ppr with zero.
- Several output types available.
- Up to 6.000 rpm speed rotation
- IP55 sealing



hollow shaft INCREMENTAL ENCODERS

Ordering code

Full stop to separate special versions.

EL 50 G 1000 Z 5/28 P 8 X 3 P R . XXX

Incremental encoder series **EL**

Body dimension **50**

Type of flanges

- blind hole fixed with spring **F**
- blind hole fixed with pin **G**
- with blind hole fixed with screw **K**

Resolutions

from **1** to **2048** PPR
Please, directly contact our offices for pulses availability

Zero pulse

- without zero pulse **S**
- with zero pulse **Z**

Input voltage

Input voltage **5 ÷ 28**
LINE DRIVER available only with input voltage 5 Vdc 8 ÷ 24 Vdc

R radial

R.P.M.

- 3** 3000
- 6** 6000 *with Enclosure rating "S" 3000 RPM*

Enclosure rating

- X** standard IP40
- S** optional IP55

Bore diameter

- 6** ø 6 H7 mm
- 8** ø 8 H7 mm
- 9** ø 9,52 H7 mm (3/8")
- 10** ø 10 H7 mm

Output types

- N** NPN
- C** NPN OPEN COLLECTOR
- P** PUSH PULL
- L** LINE DRIVER

For optionals about output types please refer to incremental outputs section

EL50 F/G/K

EL 50 F

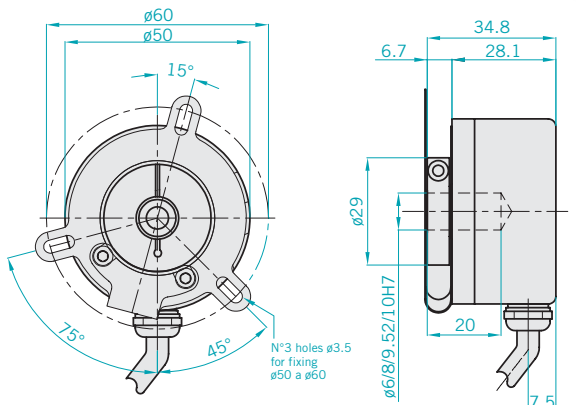

EL 50 G

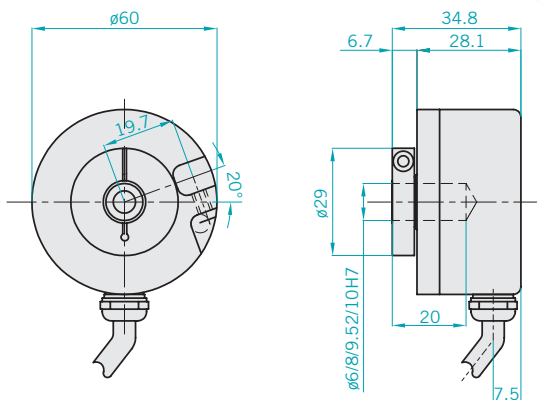

EL 50 K

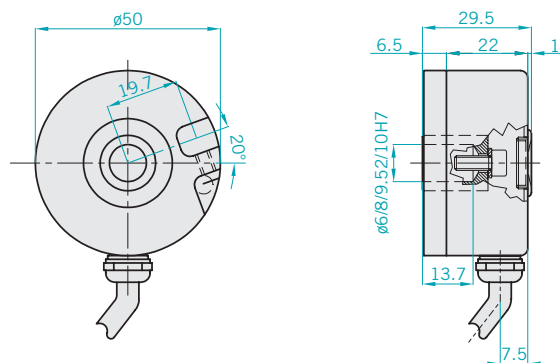

HOW TO MOUNT IT

- 1) Fix the A antirotation pin
- 2) Insert the encoder on the motor shaft with misalignment recuperation system corresponding to the A pin
- 3) Insert the B washer on the back and block it using the encoder screw on the motor axle
- 4) Phase the encoder
- 5) Fix the encoder shaft by the metal gear.
- 6) Close the encoder with the C cover.

Electrical specifications

Resolution	from 1 to 2048 PPR
Input voltage	5 ÷ 28 Vdc <i>LINE DRIVER available only with input voltage 5/8 ÷ 24 Vdc</i>
Input current with no output load	150 mA Max
Source and sink current	30 mA for channel 15 mA for channel LINE DRIVER
Output types	NPN / NPN OPEN COLLECTOR / PUSH PULL / LINE DRIVER
Output frequency	150 KHz Max
Frequency response	$F = \frac{\text{RPM} \times \text{Resolution}}{60}$

Mechanical specifications

Bore diameter	ø6 - ø8 - ø9.52 (3/8") - ø10 mm H7
Enclosure rating	IP40 - Standard IP55 - Optional
Shaft speed	3000 RPM 6000 RPM 3000 RPM MAX with "S" rating
Shock	50 G for 11 msec
Vibrations	5G 10 ÷ 500 Hz
Bearings life	10 ⁹ revolutions
Bearings	n° 2 ball bearings
Shaft material	Stainless steel AISI303
Body material	Aluminium D11S - UNI 9002/5
Housing material	Aluminium D11S - UNI 9002/5
Operating temperature	0° ÷ +60°C
Storage temperature	-25° ÷ +70°C

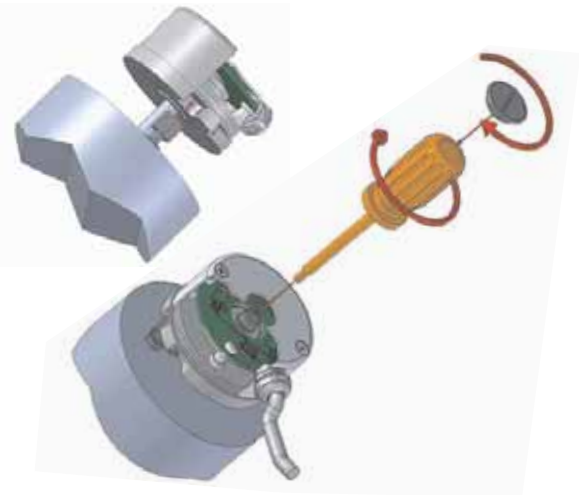



EL50 FA/FP/GA/GP INCREMENTAL ENCODER



Incremental encoder

- Ø50 encoder series used on motors.
- Several way to fix it
- Easy mechanical mounting
- Contained dimensions
- Up to 2.048 ppr with zero
- Several output types available
- Up to 6.000 rpm speed rotation
- IP55 sealing



hollow shaft INCREMENTAL ENCODERS

EL50 FA/FP/GA/GP

Ordering code

Full stop to separate special versions.

EL 50 G P 1000 Z 5/28 P 8 X 3 P R . XXX

Incremental encoder series **EL**

Body dimension **50**

fixed with spring **F**
fixed with pin **G**

encoder with front side fixing **A**
encoder with back side fixing **P**

Resolutions

from **1** to **2048** PPR

Please, directly contact our offices for pulses availability

Zero pulse

without zero pulse **S**
with zero pulse **Z**

Input voltage

input voltage **5 ÷ 28**

LINE DRIVER available only with input voltage 5 Vdc 8 ÷ 24 Vdc

R.P.M.

3 3000
6 6000

Enclosure rating

X standard IP40
S optional IP55

Bore diameter

6 ø 6 H7 mm
8 ø 8 H7 mm
9 ø 9.52 H7 mm (3/8")
10 ø 10 H7 mm

Output types

N NPN
C NPN OPEN COLLECTOR
P PUSH PULL
L LINE DRIVER

For optionals about output types please refer to incremental outputs section

Special version code numbered from 001 to 999

R radial

P cable output (standard length 0,5 m)

EL 50 FA

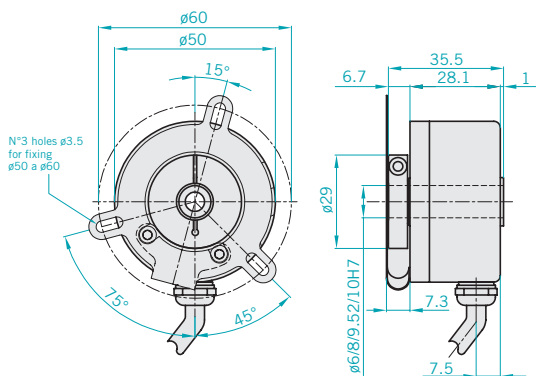

EL 50 FP

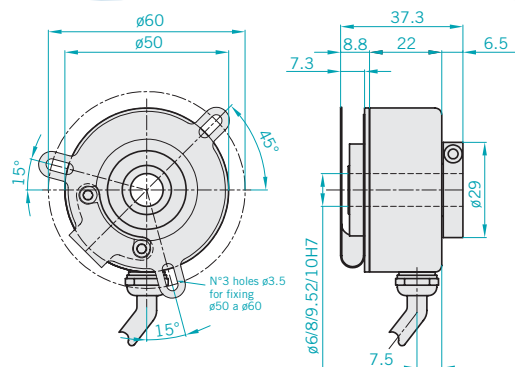

EL 50 GA

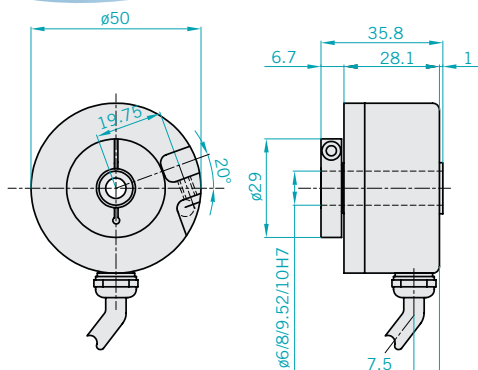

EL 50 GP

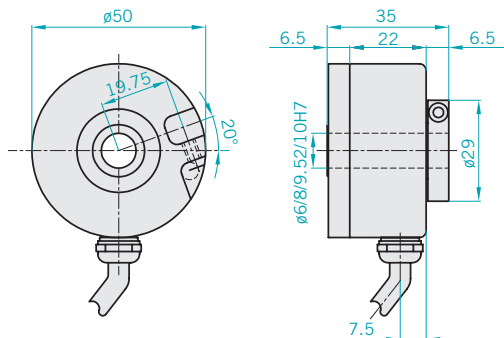

Electrical specifications

Resolution	from 1 to 2048 PPR
Input voltage	5 ÷ 28 Vdc <i>LINE DRIVER only available with input voltage 5/8 ÷ 24 Vdc</i>
Input current with no output load	150 mA Max
Source and sink current	30 mA for channel 15 mA for channel LINE DRIVER
Output types	NPN / NPN OPEN COLLECTOR/ PUSH PULL / LINE DRIVER
Output frequency	150 KHz Max
Frequency response	$F = \frac{\text{RPM} \times \text{Resolution}}{60}$

Mechanical specifications

Bore diameter	ø6 - ø8 - ø9.52 (3/8") - ø10 mm H7
Enclosure rating	IP40 - Standard IP55 - Optional
Shaft speed	3000 RPM 6000 RPM
Shock	50 G for 11 msec
Vibrations	5G 10 ÷ 500 Hz
Bearings life	10 ⁹ revolutions
Bearings	n° 2 ball bearings
Shaft material	Stainless steel AISI303
Body material	Aluminium D11S - UNI 9002/5
Housing material	Aluminium D11S - UNI 9002/5
Operating temperature	0° ÷ +60°C
Storage temperature	-25° ÷ +70°C

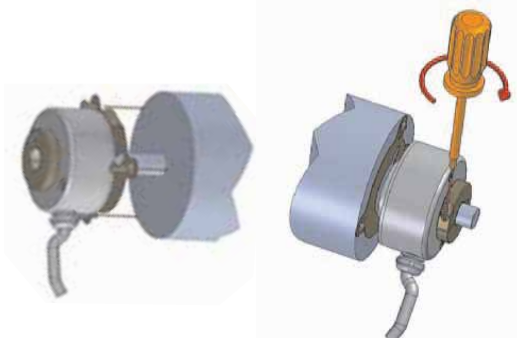

HOW TO MOUNT IT

- 1) Couple the encoder shaft with the motor shaft
- 2) Fix the spring at the motor flanges without screwing it
- 3) Fix the encoder shaft by the metal gear
- 4) Turn for phasing
- 5) Block the spring





EH- EL53A/B INCREMENTAL ENCODER



Incremental encoder

Encoder series to be mounted directly on motors. Our integrated elastic coupling allows radial and axial slack compensation

- Resolution up to 10.000 ppr with zero for EL series, up to 1024 ppr for EH series.
- Different output types available.
- Up to 28 Vdc input voltage for EL series and up to 24 Vdc for EHseries.
- Up to 300 kHz frequency response for EL series and up to 100 kHz for EH series
- Output cable with connector
- Several flanges available
- Up to 6.000 rpm speed rotation



hollow shaft INCREMENTAL ENCODERS

EH-EL53A/B

Ordering code

Full stop to separate special versions.

EL 53 A 1000 Z 5/28 N 6 X 6 M R . XXX

<p>Incremental encoder series EL</p> <p>Incremental encoder series EH</p> <p>Body dimension 53</p> <p>mod.EH-EL53A A</p> <p>mod.EH-EL53B B</p> <p>Resolutions</p> <p>from 1 to 10000 PPR series EL</p> <p>from 40 to 1024 PPR series EH</p> <p><i>Please, directly contact our offices for pulses availability</i></p> <p>Zero pulse</p> <p>without zero pulse S</p> <p>with zero pulse Z</p> <p>Input voltage</p> <p>input voltage series EL 5 ÷ 28</p> <p>input voltage series EH 5 / 8 ÷ 24</p> <p><i>LINE DRIVER available only with input voltage 5 Vdc 8 ÷ 24 Vdc</i></p>	<p>R radial</p> <p>A axial(only EL 53)</p> <p>P cable output (standard length 1,5 m series EL)</p> <p>cable output (standard length 0,5 m series EH)</p> <p>M connector MS3106E 16S-1S or 18-1S only EL53</p> <p>J connector JMSP 1607 or 1610 only EL53</p> <p>R.P.M.</p> <p>3 3000</p> <p>6 6000</p> <p>Enclosure rating</p> <p>X standard IP54 EH53</p> <p>standard IP64 EL53</p> <p>Bore diameter</p> <p>6 ø 6 H7 mm</p> <p>8 ø 8 H7 mm</p> <p>10 ø 10 H7 mm</p> <p>Output types</p> <p>N NPN</p> <p>C NPN OPEN COLLECTOR</p> <p>P PUSH PULL</p> <p>L LINE DRIVER</p> <p><i>For optional about output types please refer to incremental outputs section</i></p>	<p>Special version code numbered from 001 to 999</p>
---	--	--

EH53 A

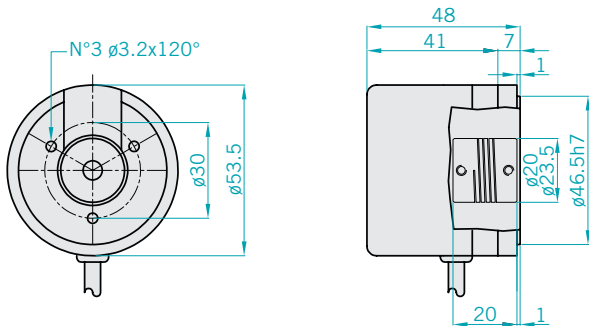

EL 53 A

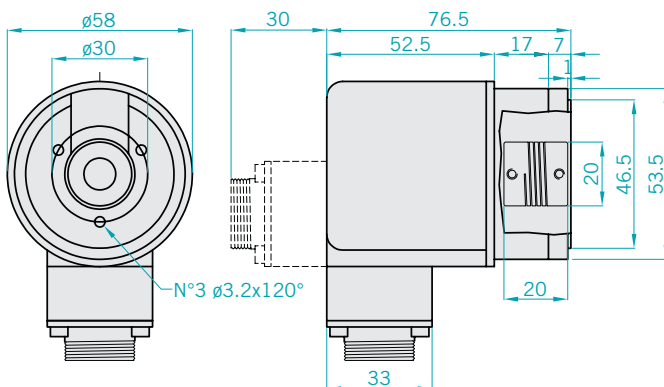

Flange version EH-EL53B

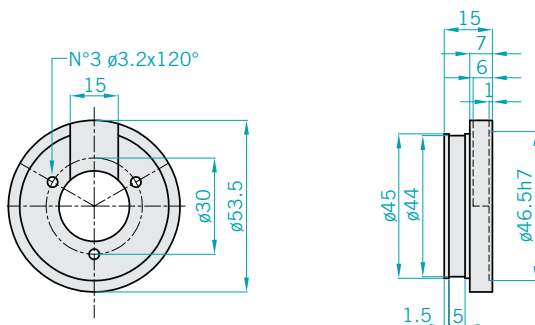

EL series electrical specifications

Resolution	from 1 to 10000 PPR
Input voltage	5 ÷ 28 Vdc LINE DRIVER only available with input voltage 5/8 ÷ 24 Vdc
Input current with no output load	100 mA MAX
Source and sink current	50 mA for channel 20 mA for channel with LINE DRIVER
Output types	NPN / NPNOPEN COLLECTOR/ PUSH PULL / LINE DRIVER
Frequency response	100 KHz MAX $F = \frac{RPM \times Resolution}{60}$

EL series electrical specifications

Resolution	from 40 a 1024 PPR
Input voltage	5Vdc / 8 ÷ 24 Vdc
Input current with no output load	100 mA Max
Source and sink current	50 mA for channel 20 mA for channel with LINE DRIVER
Output types	NPN / NPNOPEN COLLECTOR/ PUSH PULL / LINE DRIVER
Frequency response	100 KHz Max $F = \frac{RPM \times Resolution}{60}$

Mechanical specifications

Bore diameter	$\phi 6 / 8 / 10$ mm h7
Enclosure rating	EH53 : IP54 standard EL53 : IP64 standard
Shaft speed	3000 RPM 6000 RPM
Shock	50 G for 11 msec (with plastic disc) 20 G for 11 msec (with glass disc)
Vibrations	10G 10 ÷ 2000 Hz
Bearings life	10^9 revolu-
Bearings	n° 2 ball bearings
Shaft material	Stainless steel AISI303
Body material	Aluminium D11S - UNI 900/5
Housing material	PA 66 reinforced with fiber glass
Operating temperature	$0^\circ \div +60^\circ C$
Storage temperature	$-25^\circ \div +70^\circ C$
Weight	EH53 : 150 g EL53 : 350 g



EH - EL58/63 INCREMENTAL ENCODER



Incremental encoder

Hollow shaft encoder series for industrial applications with high mechanical resistance requirements. Those encoders are designed to support high radial and axial shaft load and they can be mounted with flanges or servo-fasteners.

- Resolution up to 10.000 ppr with zero for EL series, up to 1024 ppr for EH series.
- Several output types available.
- Up to 28 Vdc input voltage for EL series and up to 24 Vdc for EH series.
- Up to 300 kHz frequency response for EL series and up to 100 kHz for EH series



Ordering code

Full stop to separate special versions.

<p>Incremental encoder series EL</p> <p>Incremental encoder series EH</p> <p>Body dimension 58</p> <p>Body dimension 63</p> <p>mod.EH-EL58F / EH-EL63F F</p> <p>mod.EH-EL58G / EH-EL63G G</p> <p>mod.EH-EL63P P</p> <p>mod.EH-EL63PB PB</p> <p>mod.EH-EL63GB GB</p> <p>mod.EH-EL63FB FB</p> <p>mod.EH-EL63PC PC</p> <p>mod.EH-EL63PBF PBF</p> <p>mod.EH-EL63PCF PCF</p>	<p>EL 63 G 1000 Z 5/28 N 8 X 3 M R . XXX</p> <p>from 1 to 10000 PPR series EH/EL58F/G-EL63F/G</p> <p>from 1 to 2048 PPR series EH63P/PB/GB/FB/PC/PBF/PCF</p> <p>from 40 to 1024 PPR series EH58F/G-EH63F/G</p> <p><i>Please, directly contact our offices for pulses availability</i></p>	<p>R radial</p> <p>A axial (only for EH-EL58-63F/G)</p> <p>P cable output (standard length 0.3 m)</p> <p>M connector MS3106E 16S-1S or 18-1S for EH-EL58-63F/G</p> <p>J connector JMSP 1607 F or 1610 for EH-EL58-63F/G</p> <p>R.P.M.</p> <p>3 3000</p> <p>Enclosure rating</p> <p>X standard IP54</p> <p>S IP66 (only for EH-EL58-63F/G)</p> <p>Bore diameter</p> <p>8 ø 8 mm</p> <p>9 ø 9,52 mm (3/8")</p> <p>10 ø 10 mm</p> <p>12 ø 12 mm</p> <p>14 ø 14 mm</p> <p>15 ø 15 mm</p> <p>Output types</p> <p>N NPN</p> <p>C NPN OPEN COLLECTOR</p> <p>P PUSH PULL</p> <p>L LINE DRIVER</p>	<p>Special version code numbered from 001 to 999</p>
--	--	---	--

Zero pulse

without zero pulse **S**

with zero pulse **Z**

Input voltage

input voltage EL **5 ÷ 28**

input voltage EH **5 / 8 ÷ 24**

LINE DRIVER available only with input voltage 5 Vdc 8 ÷ 24 Vdc

For optional about output types please refer to incremental outputs section

EH-EL58F/G EH-EL63F/G/FB/GB

Blind hollow shaft encoder

EH-EL 58 F/G

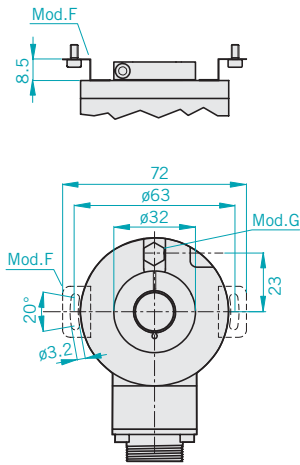

EH-EL 63 F/G

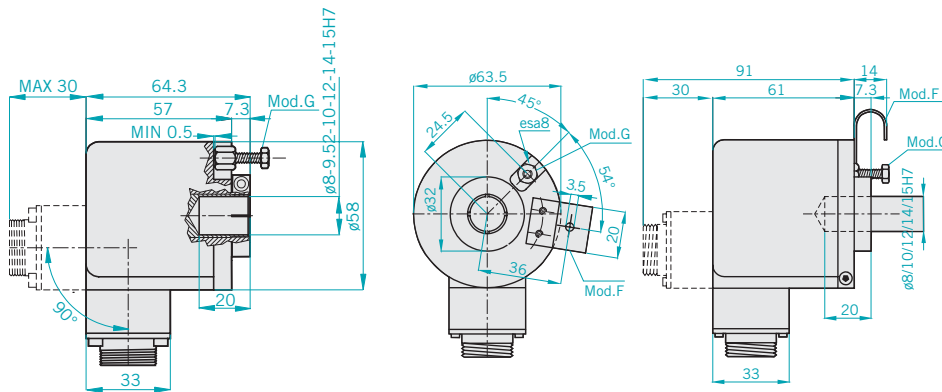

EL 63 FB

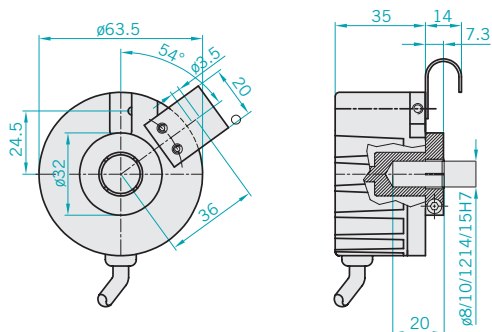

EL 63 GB

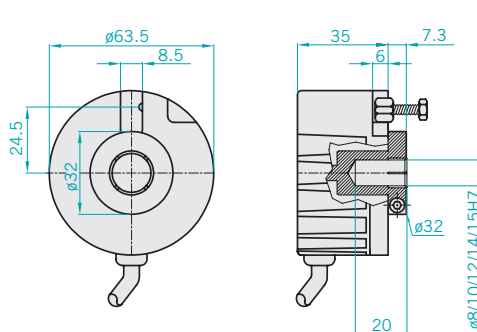

HOW TO MOUNT THE EH-EL63F

- 1) Couple the encoder shaft with the motor shaft
- 2) Fix the spring at the motor flanges without screwing it
- 3) Fix the encoder shaft by the metal gear.
- 4) Block the spring

HOW TO MOUNT THE EH-EL63G

- 1) Mount the antirotation pin on the motor flange.
- 2) Couple the encoder shaft with the motor shaft, ensuring that the pin is inserted on the cave on the encoder front part (maintaining a minimum distance of 0,5 mm)
- 3) Fix the encoder shaft by the metal ring



EH-EL63P/PB/PBF/PC/PCF

Through hollow shaft encoder

EL 63 PB / PBF

EL 63 P

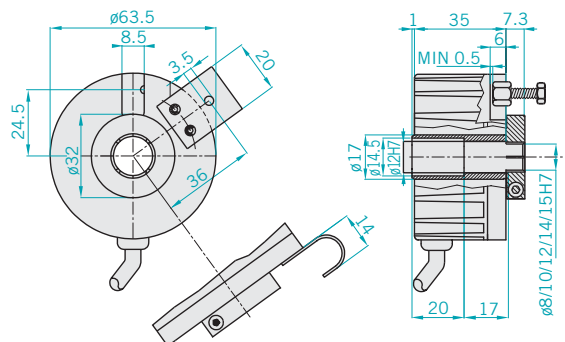
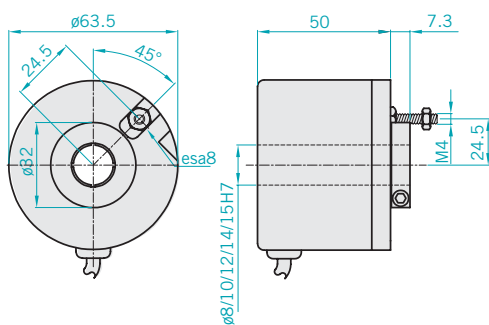

EL 63 PC

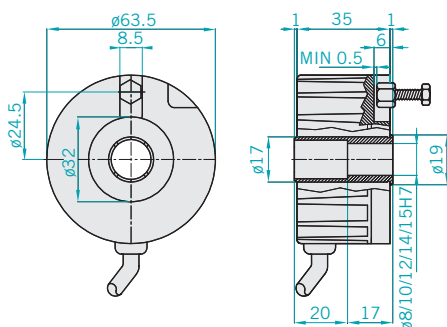

EL 63 PCF

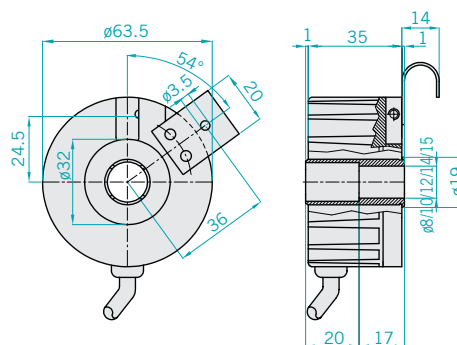

EH-EL58-63
EH-EL63P/PB/PBF/PC/PCF

HOW TO MOUNT THE EH-EL63P

- 1) Mount the antirotation pin on the motor flange.
- 2) Couple the encoder shaft with the motor shaft, ensuring that the pin is inserted on the cave on the encoder front part (maintaining a minimum distance of 0,5 mm)
- 3) Fix encoder packed shaft with the motor shaft. Insert the washer at the extremity of the encoder shaft.

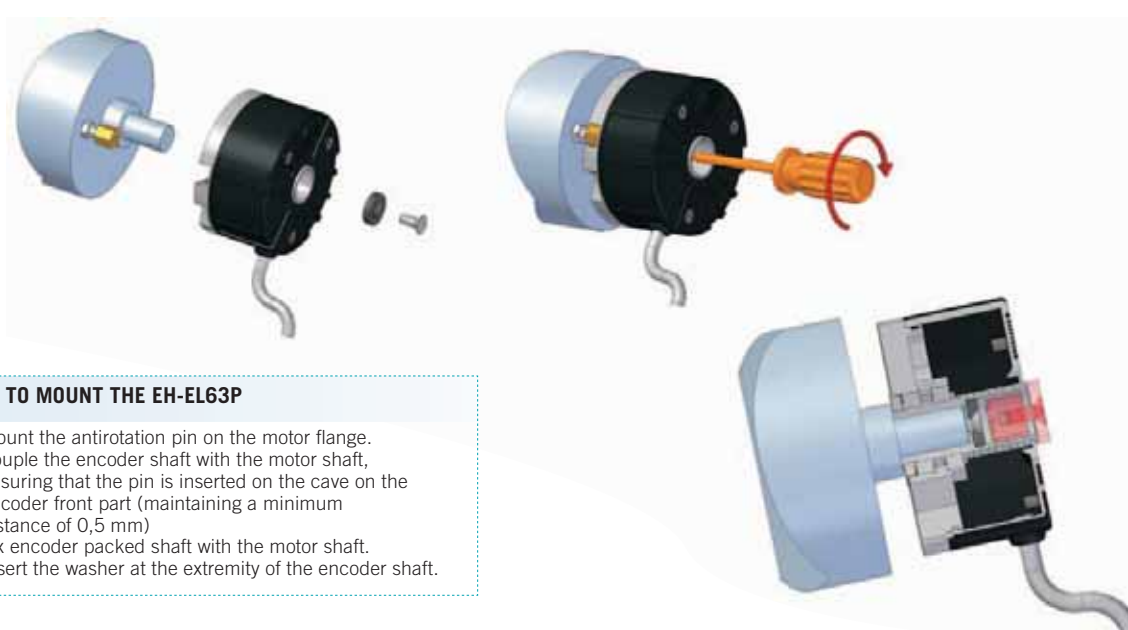

Electrical specifications series EL

Resolution	from 1 to 10000 PPR for EL58-63F/G from 1 to 2048 PPR for EL63P/PB/GB/FB/PC/PBF/PCF
Input voltage	5 ÷ 28 Vdc LINE DRIVER only available with input voltage 5/8 ÷ 24 Vdc
Input current with no output load	100 mA Max
Source and sink current	50 mA for channel 20 mA for channel with LINE DRIVER
Output types	NPN / NPNOPEN COLLECTOR/ PUSH PULL / LINE DRIVER
Frequency response	300 KHz Max $F = \frac{\text{RPM} \times \text{Resolution}}{60}$

Electrical specifications series EH

Resolution	from 40 to 1024 PPR for EH58-63F/G
Input voltage	5Vdc / 8 ÷ 24 Vdc LINE DRIVER only available with input voltage 5/8 ÷ 24 Vdc
Input current with no output load	100 mA Max
Source and sink current	50 mA for channel 20 mA for channel with LINE DRIVER
Output types	NPN / NPNOPEN COLLECTOR/ PUSH PULL / LINE DRIVER
Frequency response	100 KHz Max $F = \frac{\text{RPM} \times \text{Resolution}}{60}$

Mechanical specifications

Bore diameter	ø6-ø9,52(only mod.58)-ø10-ø12-ø14-ø15 mm H7
Enclosure rating	IP54 standard IP66 optional (only EH-EL58-63F/G)
Shaft speed	3000 RPM
Shock	50 G for 11 msec (with plastic disc) 20 G for 11 msec (with glass disc)
Vibrations	10G 10 ÷ 2000 Hz
Bearings life	10 ⁹ revolutions
Bearings	n° 2 ball bearings
Shaft material	Stainless steel AISI303
Body material	Aluminium UNI 5076
Housing material	PA 66 reinforced with fiber glass
Operating temperature	0° ÷ +60°C
Storage temperature	-25° ÷ +70°C
Weight	350 g

IN007IT0305A

hollow shaft INCREMENTAL ENCODERS

EH-EL58-63F/G
EH-EL63P/PB/GB/FB/PC/PBF/PCF



EH-EL 72 mod. A

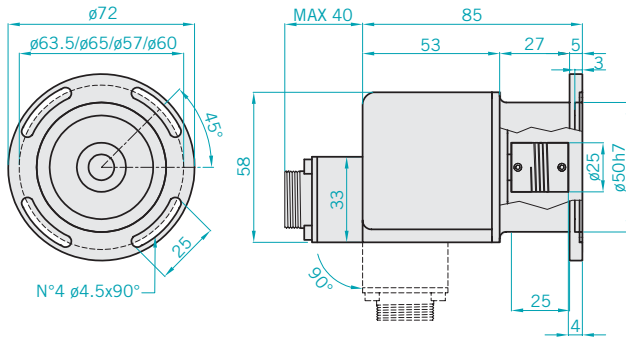

EH-EL 72 mod. B

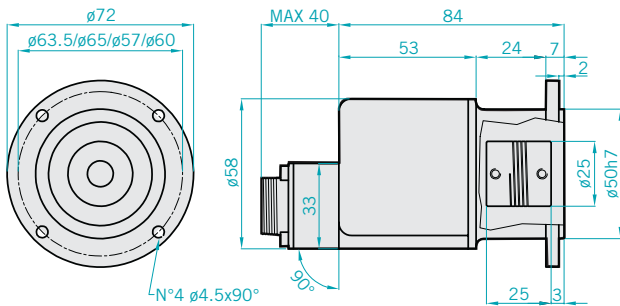

EH-EL 72 mod. A version IP66

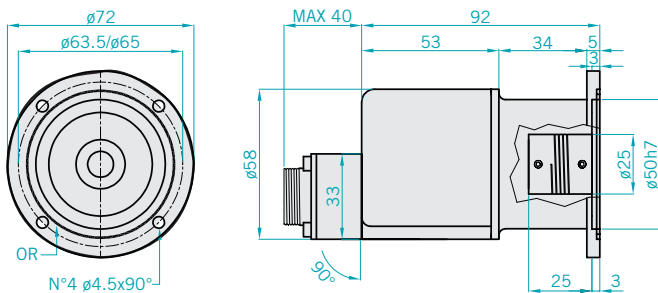

Application on tachimetric dynamo
 AVAILABLE DYNAMO A) 20V-1000 turn/min
 B) 60V-1000 turn/min

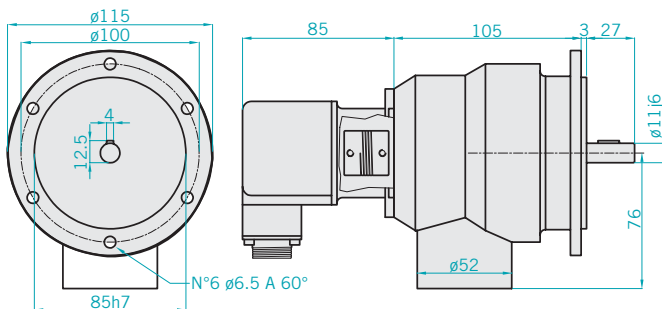

EL series electrical specifications

Resolution	from 1 to 10000 PPR
Input voltage	5 ÷ 28 Vdc LINE DRIVER only available with input voltage 5/8 ÷ 24 Vdc
Input current with no output load	100 mA Max
Source and sink current	50 mA for channel 20 mA for channel with LINE DRIVER
Output types	NPN / NPNOPEN COLLECTOR/ PUSH PULL / LINE DRIVER
Frequency response	300 KHz Max $F = \frac{RPM \times Resolution}{60}$

EH series electrical specifications

Resolution	from 40 to 1024 PPR
Input voltage	5Vdc / 8 ÷ 24 Vdc
Input current with no output load	100 mA Max
Source and sink current	50 mA for channel 20 mA for channel with LINE DRIVER
Output types	NPN / NPNOPEN COLLECTOR/ PUSH PULL / LINE DRIVER
Frequency response	100 KHz Max $F = \frac{RPM \times Resolution}{60}$

Mechanical specifications

Bore diameter	$\phi 6 / 8 / 10$ mm h7
Enclosure rating	IP54 standard IP66
Shaft speed	3000 RPM 6000 RPM 3000 turn MAX with "S" rating
Shock	50 G for 11 msec (with plastic disc) 20 G for 11 msec (with glass disc)
Vibrations	10G 10 ÷ 2000 Hz
Bearings life	10^9 revolutions
Bearings	n° 2 ball bearings
Shaft material	Stainless steel AISI303
Body material	Aluminium - UNI5076
Housing material	PA 66 reinforced with fiber glass
Operating temperature	0° ÷ +60°C
Storage temperature	-25° ÷ +70°C
Weight	400 g
Accessories	precision elastic couplings G25A6/10 G25A8/10 G25A/10



EH/EF 80C/P/K INCREMENTAL ENCODER



Motor's line Incremental encoders

Ø80 encoder series used to feedback systems on AC servomotor. They integrate a traditional incremental encoder and the optic generation of "Hall effect phases". Main characteristics are:

- Contained dimensions
- Wide resolution range available
- High temperature resistance
- Easy mounting

EH series

Basic version with incremental outputs
Several output types available

EF series

Optic engendering of the " commutation phases" integrated to the basic version
Signals transmission by parallel connection



Electrical specifications

Resolution	from 200 to 2048 not electronically multiplied
Source and sink current	15 mA for channel with LINE DRIVER 15 mA for channel with other electronics
Frequency response	300 KHz Max $F = \frac{RPM \times Resolution}{60}$

EH series electrical specifications

Input voltage	5 / 8 ÷ 24 Vdc
Output types	NPN / NPNOPEN COLLECTOR/ PUSH PULL / LINE DRIVER
Input current with no output load	100 mA Max

EF series electrical specifications

Input voltage	5 Vdc ± 5%
Output types for incremental phases	LINE DRIVER
Output types for Hall phases	NPN / NPNOPEN COLLECTOR/ PUSH PULL / LINE DRIVER
Input current with no output load	200 mA Max

Mechanical specifications

Through hole diameter EH / EF 80P (mm)	ø8 / ø10 / ø14 / 15 mm H7
Blind hole diameter EH / EF 80C (mm)	ø8FG6 / ø10G6 ø14 / ø15
Enclosure rating	IP54 standard
Shaft speed	3000 RPM
Vibrations	10G 10 ÷ 2000 Hz
Bearings life	10 ⁹ revolutions
Bearings	n° 2 ball bearings
Shaft material	Aluminium
Housing material	PA 66 reinforced with fiber glass
Operating temperature	-10° ÷ +85°C
Storage temperature	-25° ÷ +85°C
Weight	250 g

Signal configuration

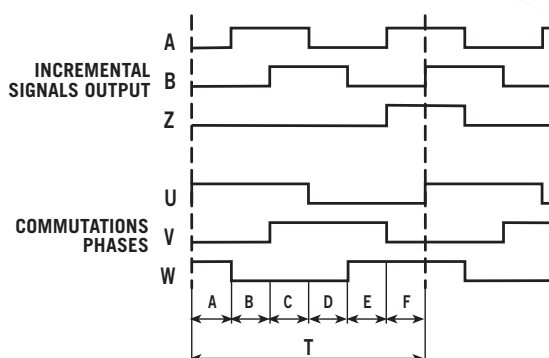

POLES	A/B/C/D/E	T
4	30° ± 1.5°	180°
6	20° ± 1.5°	120°
8	15° ± 1.5°	90°

Wire colours

COLOUR	SIGNAL	EH	EF
Red	+ Vdc	•	•
Black	0 Volt	•	•
Green	A	•	•
Yellow	B	•	•
Blue	Z	•	•
Brown	Ā	•	•
Orange	B̄	•	•
White	Z̄	•	•
Gray	U		•
Violet	V		•
Gray/Pink	W		•
Red / Blue	Ū		•
White/Green	V̄		•
Brown / Green	W̄		•



EL88P INCREMENTAL ENCODER



Incremental encoder

- Ø88 encoder series with through hollow shaft used on motors.
- Up to 38mm hole diameter
- Easy and safe fixing
- Sturdy mechanics
- Up to 2.048 ppr with Zero
- Several output types available.
- Up to 28 Vdc input voltage.
- Up to 100 kHz frequency response
- Up to 3.000 rpm speed rotation
- Up to IP54 sealing



hollow shaft INCREMENTAL ENCODERS

Ordering code

Full stop to separate special versions.

EL 88 P 500 Z 5 L 38 X 3 P R . XXX

Incremental encoder series EL	Body dimension 88	hollow shaft P	Resolutions 1 - 2048 PPR <small>Please, directly contact our offices for pulses availability</small>	Zero pulse without zero pulse S with zero pulse Z	Input voltage: input voltage 5 ÷ 28 <small>LINE DRIVER available only with input voltage 5 Vdc or 8 -24 Vdc</small>	Special version code numbered from 001 to 999	R radial	P cable output (standard length 0,5 m)	R.P.M. 3 3000	Enclosure rating X standard IP54	Bore diameter 25 ø 25 mm 30 ø 30 mm 35 ø 35 mm 38 ø 38 mm
--------------------------------------	--------------------------	-----------------------	---	---	--	--	-----------------	---	--------------------------------	--	---

Output types

N NPN

C NPN OPEN COLLECTOR

P PUSH PULL

L LINE DRIVER

For optionals about output types please refer to incremental outputs section

EL88P

EL 88

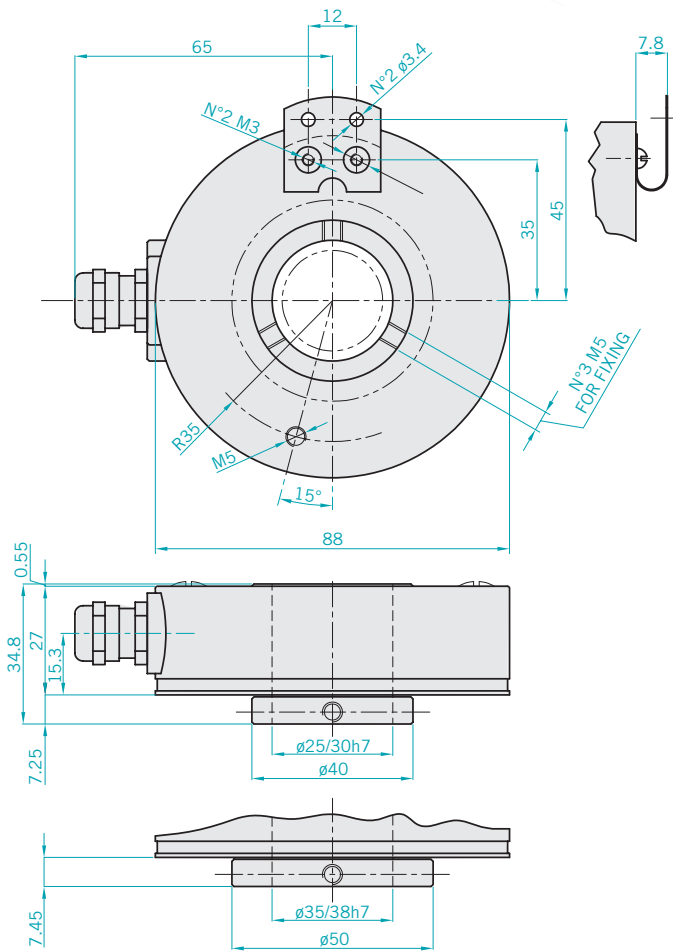

HOW TO MOUNT IT

- 1) Couple the encoder shaft with the motor shaft
- 2) Fix the spring to the motor flange without screwing it
- 3) Fix the encoder shaft by the metal gear.
- 4) Block the spring

Accessories

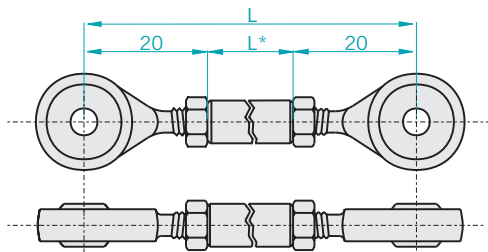

Electrical specifications

Resolution	1 - 2048 PPR
Input voltage	5 ÷ 28 Vdc LINE DRIVER only available with input voltage 5 ÷ 28 Vdc
Input current with no output load	100 mA Max
Source and sink current	50 mA for channel 20 mA for channel with LINE DRIVER
Output types	NPN / NPN OPEN COLLECTOR/ PUSH PULL / LINE DRIVER
Frequency response	100 KHz Max $F = \frac{RPM \times Resolution}{60}$

Mechanical specifications

Bore diameter	Ø25 H7 / Ø30 H7 / Ø35 H7 / Ø38 mm H7
Enclosure rating	IP54 standard
Shaft speed	3000 RPM
Bearings	n° 2 ball bearings
Shaft material	Stainless steel AISI303 for Ø35 and Ø38 Aluminium D11S UNI9002/5 for Ø25 and Ø30
Housing material	Aluminium
Operating temperature	0° ÷ +60°C
Storage temperature	-25° ÷ +70°C
Weight	350g

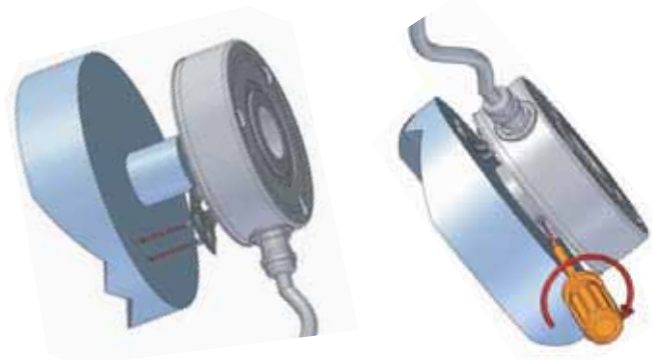

Available lengths

L* = 30 mm	Ordering code: SN5A30
L* = 60 mm	Ordering code: SN5A60
L* = 90 mm	Ordering code: SN5A90

hollow shaft INCREMENTAL ENCODERS

IN019IT0305A

EL88P





EL120P INCREMENTAL ENCODER



Incremental encoder

Ø120 encoder series with through hollow shaft used on motors.

- Up to 60mm bore diameter
- Easy and safe fixing
- Rugged mechanics
- Up to 2.048 ppr with Zero
- Several output types available. Up to 28 Vdc input voltage.
- Up to 100 kHz frequency response
- Up to 3.000 rpm speed rotation
- Up to IP54 sealing



hollow shaft INCREMENTAL ENCODERS

Ordering code

Full stop to separate special versions.

EL 120 P 500 Z 5 N 50 X 3 P R . XXX

<p>Incremental encoder series EL</p> <p>Body dimension 120</p> <p>hollow shaft P</p> <p>Resolutions 1 - 2048 PPR <i>Please, directly contact our offices for pulses availability</i></p> <p>Zero pulse without zero pulse S with zero pulse Z</p> <p>Input voltage: input voltage 5 ÷ 28 <i>LINE DRIVER available only with input voltage 5 Vdc or 8 ÷ 24 Vdc</i></p>	<p>R.P.M. 3 3000</p> <p>Enclosure rating X standard IP54</p> <p>Bore diameter 40 ø 40 mm 50 ø 50 mm 60 ø 60 mm</p> <p>Output types N NPN C NPN OPEN COLLECTOR P PUSH PULL L LINE DRIVER <i>For optionals about output types please refer to incremental outputs section</i></p>	<p>P cable output (standard length 0,5 m)</p> <p>R radial</p> <p>XXX Special version code numbered from 001 to 999</p>
--	--	---

EL120P

EL 120

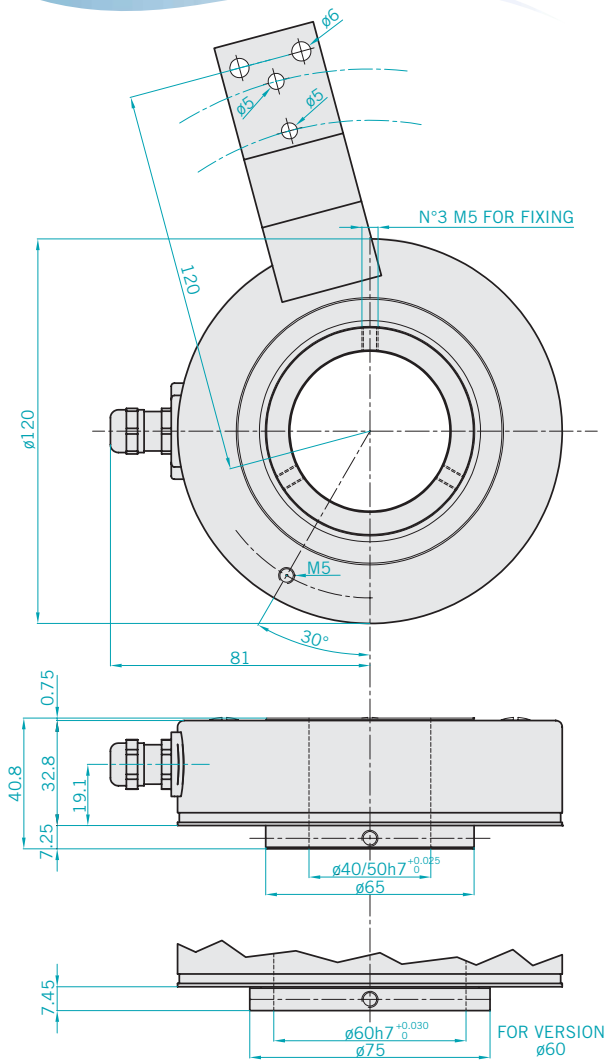

Accessories

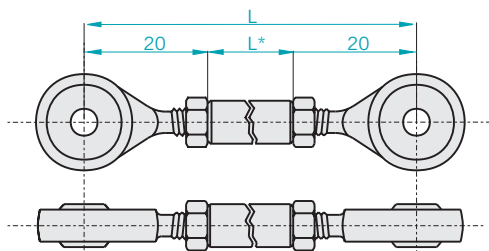

* See below for arm length

Available lengths

$L^* = 30$ mm	Ordering code: SN5A30
$L^* = 60$ mm	Ordering code: SN5A60
$L^* = 90$ mm	Ordering code: SN5A90

Electrical specifications

Resolution	1 - 2048 PPR
Input voltage	5Vdc / 8 ÷ 24 Vdc
Input current with no output load	100 mA Max
Source and sink current	50 mA for channel 20 mA for channel with LINE DRIVER
Output types	LINE DRIVER / PUSH PULL
Frequency response	100 KHz Max $F = \frac{RPM \times Resolution}{60}$

Mechanical specifications

Bore diameter	$\phi 40 / 50 / 60$ mm H7
Enclosure rating	IP54 standard
Shaft speed	3000 RPM
Bearings	n° 2 ball bearings
Shaft material	Aluminium D11 S UNI9002/5
Housing material	Aluminium
Operating temperature	0° ÷ +60°C
Storage temperature	-25° ÷ +70°C
Weight	750 g

HOW TO MOUNT IT

- 1) Couple the encoder shaft with the motor shaft
- 2) Fix the spa to the motor flange without screwing it
- 3) Fix the encoder shaft by the metal gear.
- 4) Block the spring

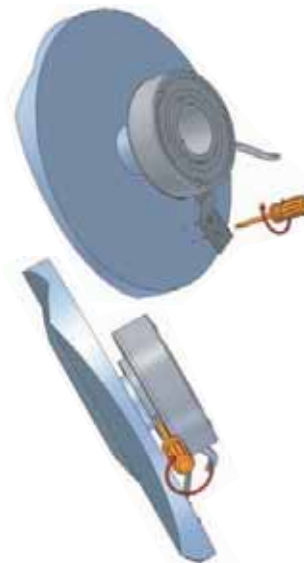

hollow shaft INCREMENTAL ENCODERS

INC20IT0305A

EL 120P



EH150

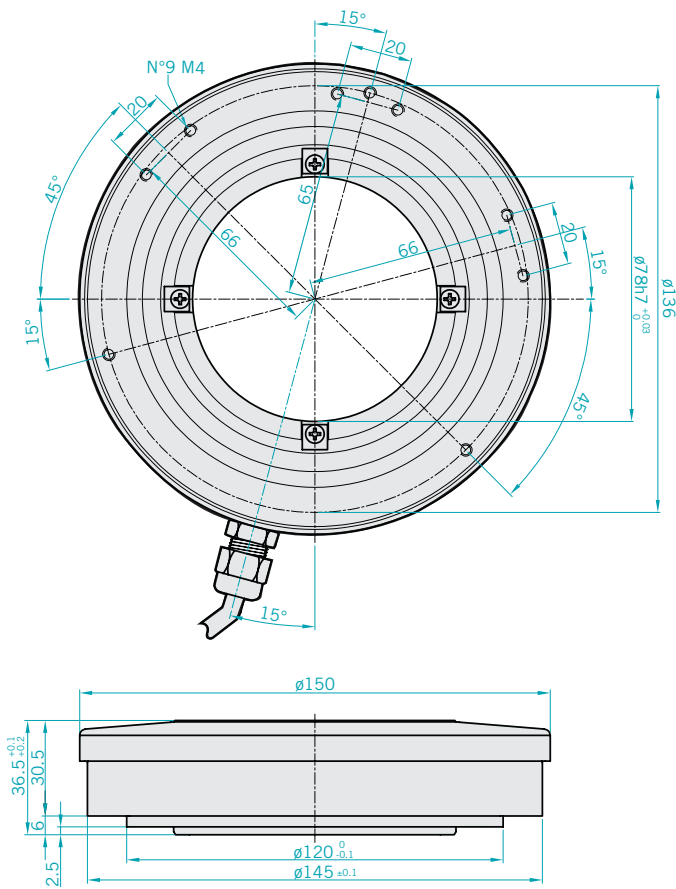

Electrical specifications

Resolution	From 1024 to 5040 PPR
Input voltage	5Vdc / 8 ÷ 24 Vdc
Input current with no output load	100 mA Max
Source and sink current	50 mA for channel 20 mA for channel with LINE DRIVER
Output types	NPN / NPN OPEN COLLECTOR/ PUSH PULL / LINE DRIVER
Frequency response	100 KHz Max $F = \frac{\text{RPM} \times \text{Resolution}}{60}$

Mechanical specifications

Bore diameter	ø50 / 60 / 70 / 78 mm H7
Enclosure rating	IP40 standard IP65 with special work condition
Shaft speed	1000 RPM
Bearings	n° 1 ball bearings
Shaft material	Aluminium D11 S UNI9002/5
Housing material	Aluminium
Operating temperature	0° ÷ +60°C
Storage temperature	-25° ÷ +70°C
Weight	1000g

Ideal working condition to obtain IP65 protection

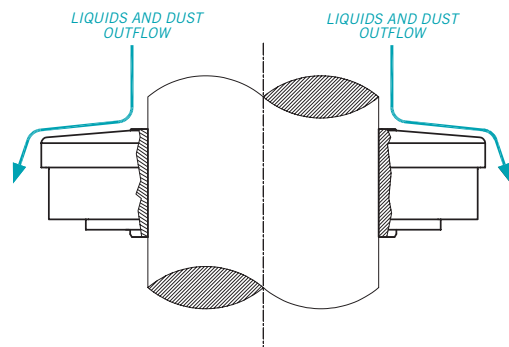

Accessories

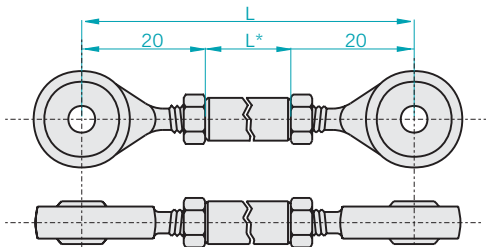

Available lengths

L* = 30 mm	Ordering code: SN5A30
L* = 60 mm	Ordering code: SN5A60
L* = 90 mm	Ordering code: SN5A90

hollow shaft INCREMENTAL ENCODERS

IN025IT0305A

EH150P





EX80A/D

EXPLOSIONPROOF ENCODER



Explosionproof encoder

Explosionproof encoders for applications within explosive and hazardous areas.

- Up to 10.000 ppr with Zero
- Several output types available. Up to 28 Vdc input voltage
- Up to 300 kHz frequency response
- Output cable
- Several flanges available
- Up to 3.000 rpm speed rotation
- Up to IP65 sealing



EN 50.014 / EN 50.018
CESI certificate number: CESI 04 ATEX 082

Ordering code

SPECIAL PRODUCTS

Full stop to separate special versions

EX 80 A 1000 Z 5/28 P 10 X 3 P R . XXX

explosionproof encoder by EExd IIC T6 standard

EX

Special version code numbered from 001 to 999

body dimension 80

R radial

Type of flanges

mod. EX80A **A**
mod. EX80D **D**

P Cable output
standard cable output 1,5 m
G threaded union 1/2" Gas

R.P.M.

3 3000

Resolutions

from **1** to **10000** PPR

Please, directly contact our offices for pulses availability

Enclosure rating

X standard IP65

Shaft diameter

10 ø 10 mm

Output types

N NPN
C NPN OPEN COLLECTOR
P PUSH PULL
L LINE DRIVER

For optional about output types please refer to incremental outputs section

EX80A/D

EX 80A

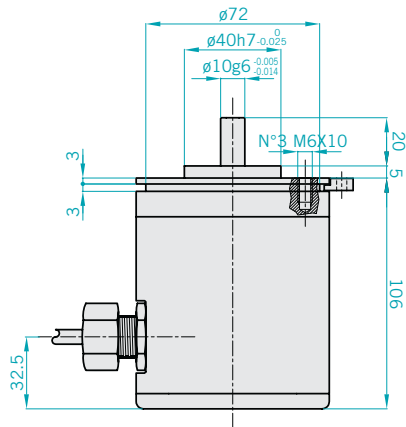

EX 80D

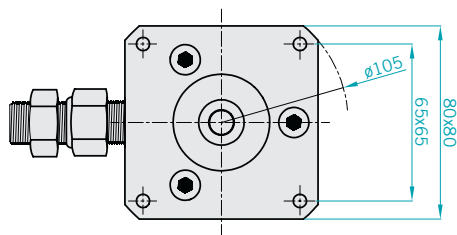
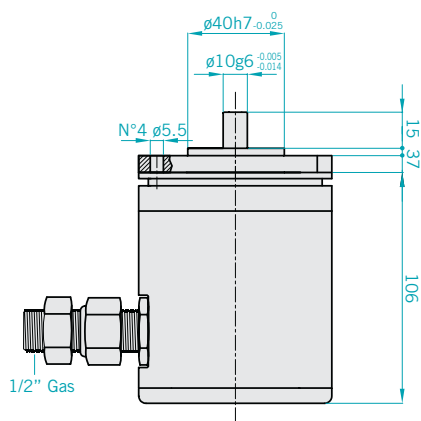

Electrical specifications

Resolution	from 1 to 10000 PPR
Input voltage	5 ÷ 28 Vdc LINE DRIVER only available with input voltage 5 ÷ 28 Vdc
Input current with no output load	100 mA MAX
Source and sink current	50 mA for channel 20 mA for channel with LINE DRIVER
Output types	NPN / NPN OPEN COLLECTOR / PUSH PULL / LINE DRIVER
Frequency response	100 KHz MAX $F = \frac{RPM \times Resolution}{60}$

Mechanical specifications

Shaft diameter	$\phi 10$ mm g6 (-0.005 / -0.014)
Shaft speed	3000 RPM
Shock	50 G for 11 msec (with plastic disc) 20 G for 11 msec (with glass disc)
Vibrations	10G 10 ÷ 2000 Hz
MAX shaft load	200 N (20 Kp) axial 200 N (20 Kp) radial
Bearings life	10 ⁹ revolutions
Bearings	n°2 ball bearings
Shaft material	Steel AISI303
Housing material	Aluminium D11S - UNI9002/5
Operating temperature	0° ÷ +60°C
Storage temperature	-25° ÷ +70°C
Weight	1200g

Explosionproof encoder EExdIIC T6



EN 50.014 / EN 50.018
CESI certification number: CESI 04 ATEX 082

EExdIIC T6

EEx: Electrical system for explosive and hazardous areas

d: Explosionproof box

II: Electrical system which can operate in hazardous areas except for the mines where "grisou" gas is present

C: Type of protection based on the special interstice designed to have the maximum security on the explosionproof encoder (MESG) C=maximum security

T6: Maximum encoder surface temperature 85° C





EC34 ENCODER FOR RACKS



Encoder for racks

Rack encoders with automatic slack recovery. If compared to an incremental linear system, this type of encoder extremely simplifies linear measurements and overcomes measurement problems on long distance. Our models are sealed in a robust aluminium body and integrate a preload system allowing the automatic slack recovery between rack and pinion.

- Up to 2.000 ppr with zero
- Several output types available.
Up to 24 Vdc input voltage.
- Up to 300 kHz frequency response
- Output cable with connector.



SPECIAL PRODUCTS

Ordering code

Full stop to separate special versions

EC34 A 100 Z 5 N 10 M . XXX

encoder for racks

EC34

Special version code
numbered from 001 to 999

Type of flanges
mod. EC34A A

P Cable output
standard length 1,5 m
M connector MS3106S-1S or 18-1S
J connector JMSP 1607 F or 1610 F

Resolutions

from 1 to 2000 PPR

Please, directly contact our offices for pulses availability

Shaft diameter

10 \varnothing 10 mm

Zero pulse

without zero pulse S
with zero pulse Z

Output types

N NPN
C NPN OPEN COLLECTOR
P PUSH PULL
L LINE DRIVER

For optionals about output types please refer to incremental outputs section

Input voltage

5
input voltage 8 ÷ 24

EC34

EC34A

*3mm total preload stroke

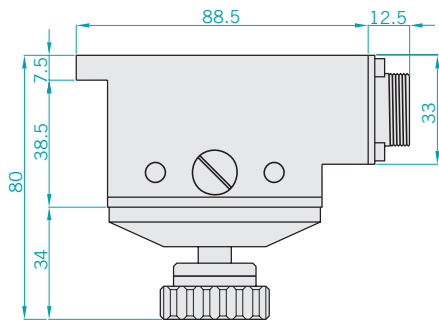
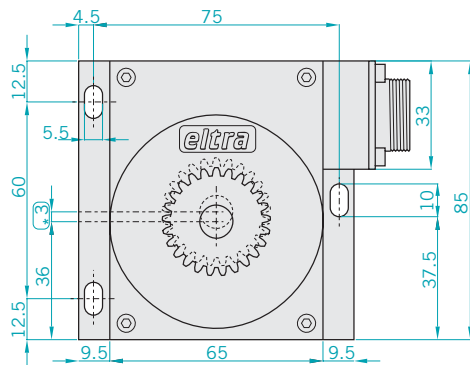

Rack and toothed wheel
 $p=2.5 / z=40 / m=0.796$

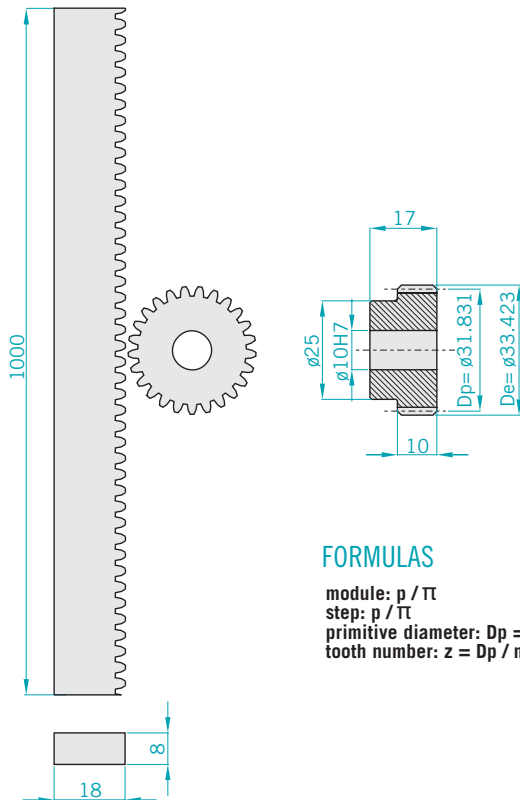

FORMULAS

module: p / π
 step: p / π
 primitive diameter: $Dp = mz$
 tooth number: $z = Dp / m$

Electrical specifications

Resolution	from 1 to 2000 PPR
Input voltage	5Vdc / 8 ÷ 24 Vdc
Input current with no output load	100 mA MAX
Source and sink current	50 mA for channel 20 mA for channel with LINE DRIVER
Output types	NPN / NPN OPEN COLLECTOR / PUSH PULL / LINE DRIVER
Output frequency	100 KHz MAX
Frequency response	$F = \frac{\text{RPM} \times \text{Resolution}}{60}$

Mechanical specifications

Shaft diameter	ø10 mm g6
Enclosure rating	IP64 - standard
Shaft speed	3000 RPM
Allowed weights on the shaft	200 N (20 Kp) axial 200 N (20 Kp) radial
Shock	50 G for 11 msec
Vibrations	10G 10 ÷ 2000 Hz
Bearings life	10 ⁹ revolutions
Bearings	n°2 ball bearings
Shaft material	Steel AISI303
Housing material	Epidoxic oven-painted aluminium
Rack material	Steel
Operating temperature	0° ÷ +60°C
Storage temperature	-25° ÷ +70°C
Weight	700gr

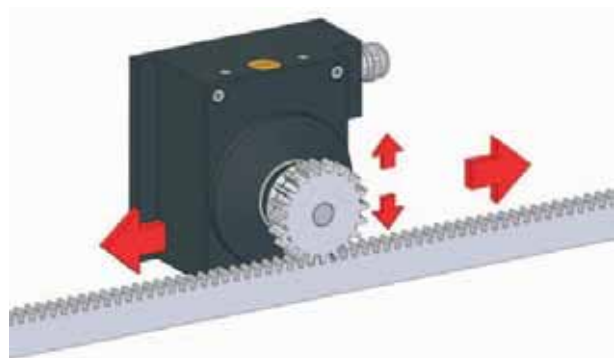

SPECIAL PRODUCTS

IN011IT0305A

EC34





RH200A/B/C RH-RM500A/B/C METRIC WHEELS



Metric wheels

Eltra's metric wheels series is studied for specific industrial application where is required to measure a linear movement (i.e. continuous sheet cutting machines of wood, textiles, glass, etc.). Precise reading and high stress resistance are the main features of those encoders. The body is entirely designed of aluminium and mounted using an oscillating arm pivoted on the axial. It comes with an integrated self-lubricating compact box to assure a long operation period without any maintenance. The weighty metric wheel keeps a stable contact with the material, allowing an accurate measurement of both length and speed. The wheel surface can be in crossed-knurl aluminium, special anti-oil or anti-slide rubber.



Ordering code

Full stop to separate special versions

RH	200	A	500	Z	5	N	8	X	3	P	R	XXX
support RH200-500 RH support RM500 RM	200mm linear wheel 200 500mm linear wheel 500	Wheel type smooth A knurled B rubberized C								P cable output (standard length 0,5 m for RH200) cable output (standard length 1,5 m for RH-RM500) M connector MS3106E 16S-1S o 18-1S J connector JMSP 1607 F o 1610 F <small>M and J connectors only available for metric wheels RH-RM500 series</small>	R radial A axial	Special version code numbered from 001 to 999
			Resolutions from 1 to 10000 PPR series RM500 from 40 to 1024 PPR series RH200/500 <small>Please, directly contact our offices for pulses availability</small>						R.P.M. 3 3000	Enclosure rating X standard IP54 RH200 standard IP64 RH-RM500 S optional IP66		
			Zero pulse without zero pulse S with zero pulse Z					Bore diameter 8 ø 8 mm RH200 10 ø 10 mm RH-RM500				
			Input voltage series RM500 5 ÷ 28 series RH200/500 5 / 8 ÷ 24 <small>LINE DRIVER only available with input voltage 5 Vdc or 8 ÷ 24 Vdc</small>					Output types N NPN C NPN OPEN COLLECTOR P PUSH PULL L LINE DRIVER <small>For optionals about output types please refer to incremental outputs section</small>				

SPECIAL PRODUCTS

RH200A/B/C
RH-RM500A/B/C

RH200

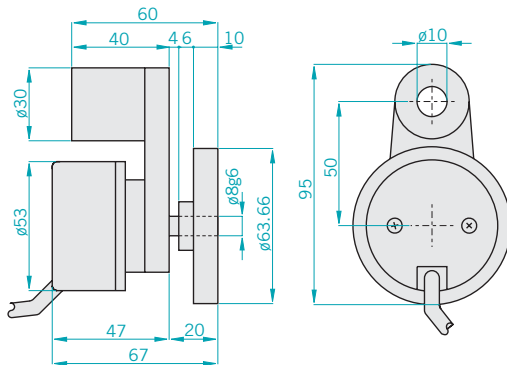

RH500

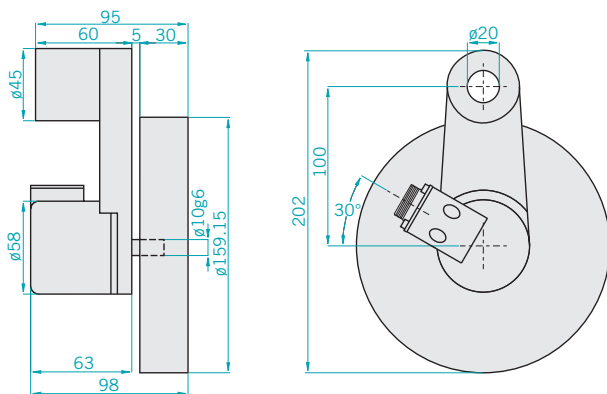

RM500

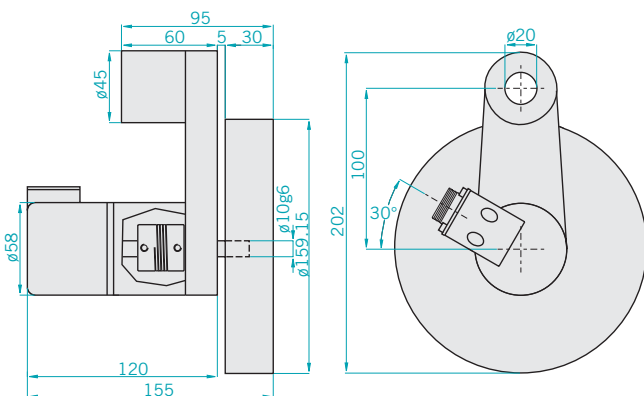

RM 500 series electrical specifications

Resolution	from 1 to 10000 PPR
Input voltage	5 ÷ 28 Vdc LINE DRIVER only available with input voltage 5/8 ÷ 24 Vdc
Input current with no output load	100 mA MAX
Source and sink current	50 mA for channel 20 mA for channel with LINE DRIVER
Output types	NPN / NPN OPEN COLLECTOR / PUSH PULL / LINE DRIVER
Frequency response	300 KHz MAX $F = \frac{RPM \times Resolution}{60}$

RH200 series electrical specifications

Resolution	from 40 to 1024 PPR
Input voltage	5Vdc / 8 ÷ 24 Vdc
Input current with no output load	100 mA MAX
Source and sink current	50 mA for channel 20 mA for channel with LINE DRIVER
Output types	NPN / NPN OPEN COLLECTOR / PUSH PULL / LINE DRIVER
Frequency response	100 KHz MAX $F = \frac{RPM \times Resolution}{60}$

Mechanical specifications

Bore diameter	ø8 mm g6 RH200 ø10 mm g6 RH-RM500
Enclosure rating	IP54 standard for RH200 IP64 standard for RH-RM500 IP66 optional (only RH-RM500)
Shaft speed	3000 RPM
Shock	50 G for 11 msec (with plastic disc) 20 G for 11 msec (with glass disc)
Vibrations	10G 10 ÷ 2000 Hz
Bearings life	10 ⁹ revolutions
Bearings	n° 2 ball bearings +n° 2 ball bearings on support for RM500
Shaft material	Stainless steel AISI303
Housing material	Aluminium - UNI 5076
Support material	Aluminium - UNI 9002/5 painted
Wheel material	Aluminium - UNI 9002/5 for Sv.200
Operating temperature	0° ÷ +60°C
Storage temperature	-25° ÷ +70°C
Weight + support	250g for RH200 1000g for RM500
Wheels weights	100g for Sv.200 800g for Sv.500

SPECIAL PRODUCTS

IN012IT0305A

RH200A/B/C
RH-RM500A/B/C





ER A/B/C INCREMENTAL LINEAR SYSTEM



Incremental linear system

- Working stroke up to 500mm
- Available with or without zero on left, right or central position.
- Several electronic output configurations available. Up to 24 Vdc Power supply.
- Output cable. Cable connector available on request.



SPECIAL PRODUCTS

Ordering code

Full stop to separate special versions

ER A 100 D 5 N 6 P . XXX

Eltra's incremental linear system **ER**

Resolutions

- 0,2 mm (0,05 by reading each front) **A**
- 0,1 mm (0,025 by reading each front) **B**
- 0,04 mm (0,01 by reading each front) **C**

from **100** to **500** working stroke

without zero index **S**
 central zero index **C**
 right zero index (closed position) **D**
 left zero index (open position) **Z**

Input voltage:
 5
 8 ÷ 24

Assemblig hole diameter
 6 ø 6 mm

Output types

- N** NPN
- C** NPN OPEN COLLECTOR
- P** PUSH PULL
- L** LINE DRIVER

For optionals about output types please refer to incremental outputs section

XXX Special version code numbered from 001 to 999

P Cable output type IPON IP67 standard length 1,5 m

ER A/B/C

ERA/B/C

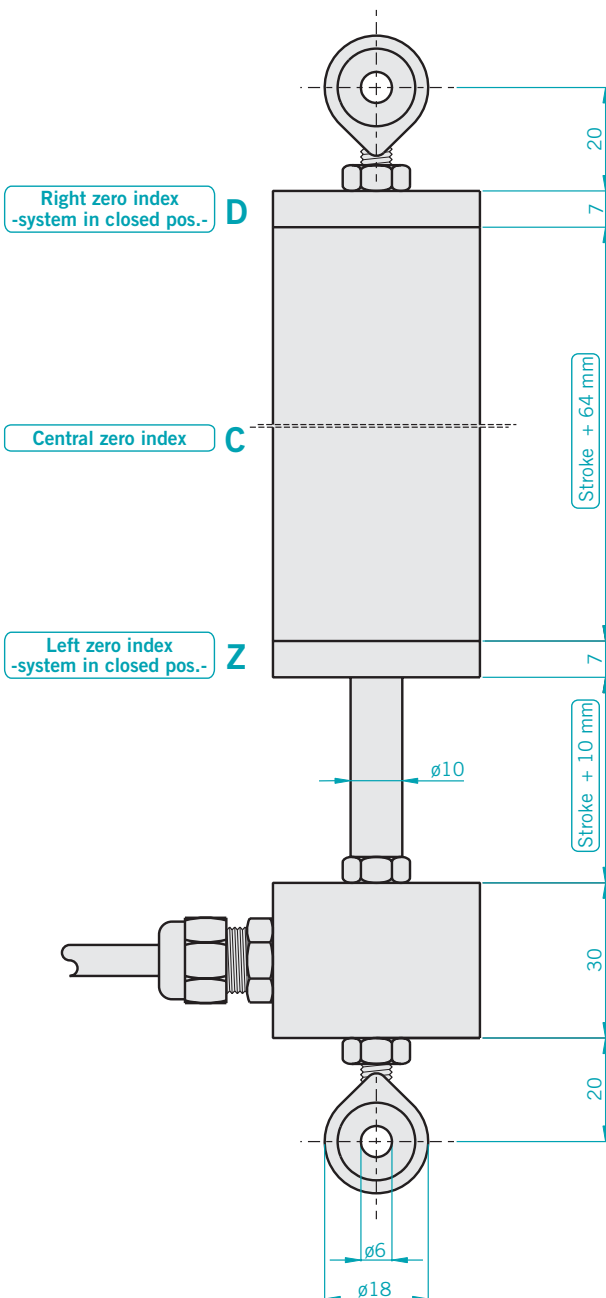
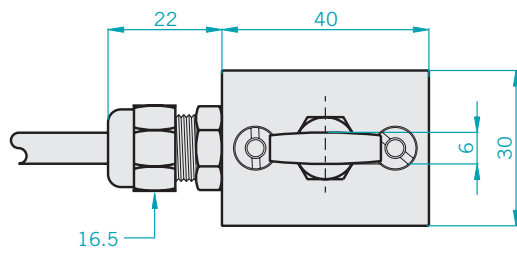

Electrical specifications

Resolution	0,2 mm (0,05 by reading each front) 0,1 mm (0,025 by reading each front) 0,04 mm (0,01 by reading each front)
Repeatability	+/- 0,05 mm for ERA +/- 0,025 mm for ERB +/- 0,01 mm for ERC
Input voltage	5 Vdc / 8 ÷ 24 Vdc
Input current with no output load	50 mA MAX
Source and sink current	50 mA for channel 20 mA for channel with LINE DRIVER
Output types	NPN / NPN OPEN COLLECTOR / PUSH PULL / LINE DRIVER

Mechanical specifications

Working stroke	from 100 to 500
Enclosure rating	IP64 standard
Max movement speed	60 m/min.
Shock	50 G for 11 msec
Vibrations	10 G 10 2000 Hz
Body material	Stainless steel AISI303
Housing material	Aluminium UNI 6362 verniciato
Fixing	n° 2 rod heads with hole size $\phi 6$
Operating temperature	0° ÷ +60°C
Storage temperature	-25° ÷ +70°C
Weight	from 400g to 1000g



SPECIAL PRODUCTS

IN0131T0305A

ER A/B/C





EV A/B/C ELECTRONIC HAND WHEEL



Electronic hand wheel

Electronic hand wheels series studied for positioning on the numerical control machines with manual drive.

- Resolution up to 10.000 ppr with zero
- Several electronic output configurations available. Up to 28 Vdc power supply.
- Output frequency up to 100 kHz
- Output cable with connector and several flanges available



Ordering code

Full stop to separate special versions

EV	A	M	100	Z	5	L	10	M	R	.	XXX
Electronic hand wheel	Type of flanges										Special version code numbered from 001 to 999
EV	mod. EV A mod. EV B mod. EV C	with grip handle without grip handle							A axial (only EVA/B) R radial		
			Resolutions						P cable output (standard length 1,5 m for EVA/B) cable output (standard length 0,3 m for EVC)		
			from 1 to 10000 PPR for EV A/B 100 PPR for EV C <i>Please, directly contact our offices for pulses availability</i>						M connector M53106E 165-15 or 18-15 for EVA/B J connector JMSP 1607 F or 1610 F for EVA/B		
			Zero pulse						Shaft diameter		
			without zero pulse with zero pulse						6 ø 6 g6 mm (EVC) 10 ø 10 g6 mm (EVA/B)		
			Input voltage:						Output types		
			(EVC available only with 5 Vdc) 5 5 ÷ 28 <i>LINE DRIVER available only with 5 Vdc or 8 ÷ 24 Vdc</i>						N NPN C NPN OPEN COLLECTOR P PUSH PULL L LINE DRIVER <i>For optionals about output types please refer to incremental outputs section</i>		

EVA

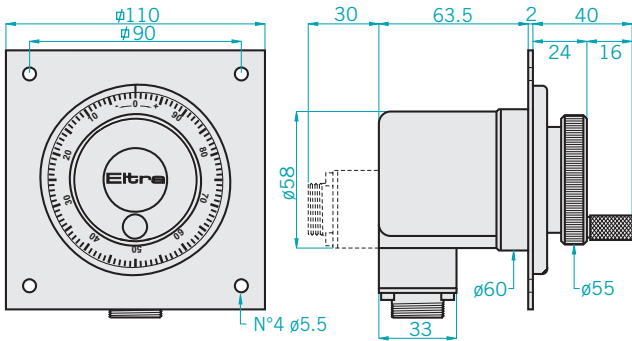

EVB

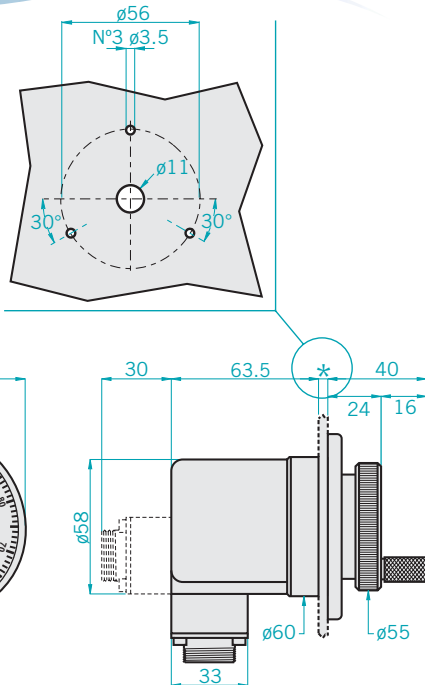

EVC

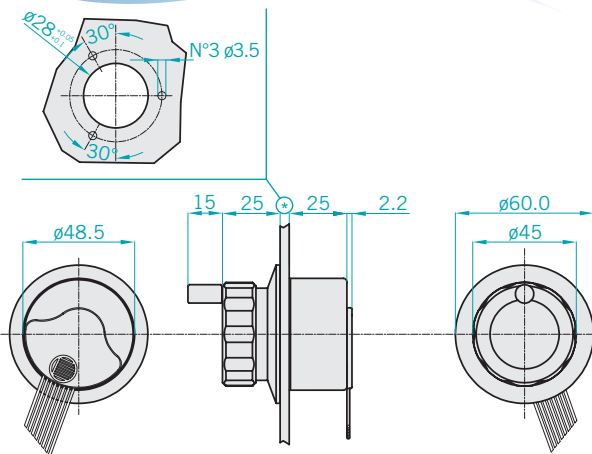

Electrical specifications

Resolution	from 1 to 10000 PPR for EVA/B 100 PPR for EVC
Input voltage	5 Vdc for EVC 5 Vdc / 5 ÷ 28 for EVA/B LINE DRIVER only available with input voltage 5/8-24 Vdc
Input current with no output load	100 mA MAX
Source and sink current	50 mA for channel 20 mA for channel with LINE DRIVER
Output types	NPN / NPN-OPEN COLLECTOR / PUSH PULL / LINE DRIVER
MAX output frequency	100 kHz MAX
Frequency response	$F = \frac{\text{RPM} \times \text{Resolution}}{60}$

Mechanical specifications

Shaft diameter	$\phi 6$ mm g6 for EVC $\phi 10$ mm g6 for EVA/B
Enclosure rating	IP64 standard for EVA/B IP40 standard for EVC
Mechanical lines per turn	100
Shock	50 G for 11 msec
Vibrations	10G 10 ÷ 2000 Hz
Bearings life	10^9 revolutions
Bearings	n° 2 ball bearings
Shaft material	Stainless steel AISI303
Housing material	Aluminium D11S - UNI 9002/5
Housing material	PA 66 reinforced with fiber glass for EVA/B Fe for EVC
Operating temperature	$0^\circ \div +60^\circ\text{C}$
Storage temperature	$-25^\circ \div +70^\circ\text{C}$
Weight	150g for EVC 450g for EVA/B

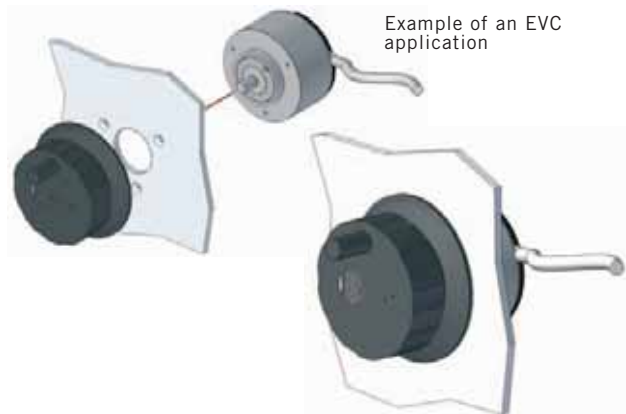



FE ROPE ENCODER



Incremental encoder

Rope extension encoder series available for lengths up to 8 mt. and resolutions up to 0,01 mm. The mounted encoder could be incremental or absolute, both available with SSI or PROFIBUS interface.

Perfectly suitable also for critical environments, considering the high mechanical resistance characteristics.

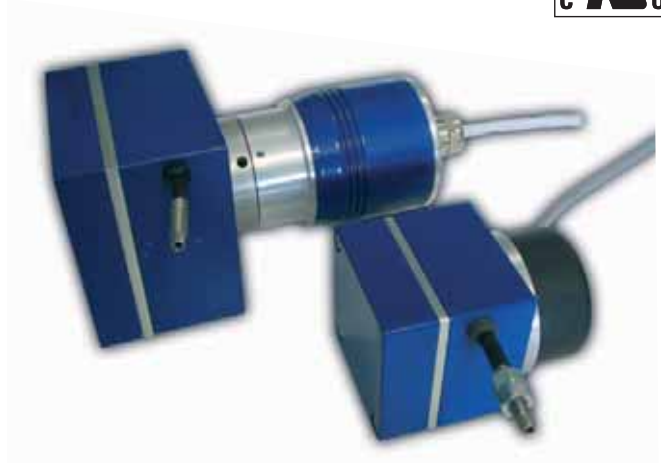

SPECIAL PRODUCTS

Ordering code

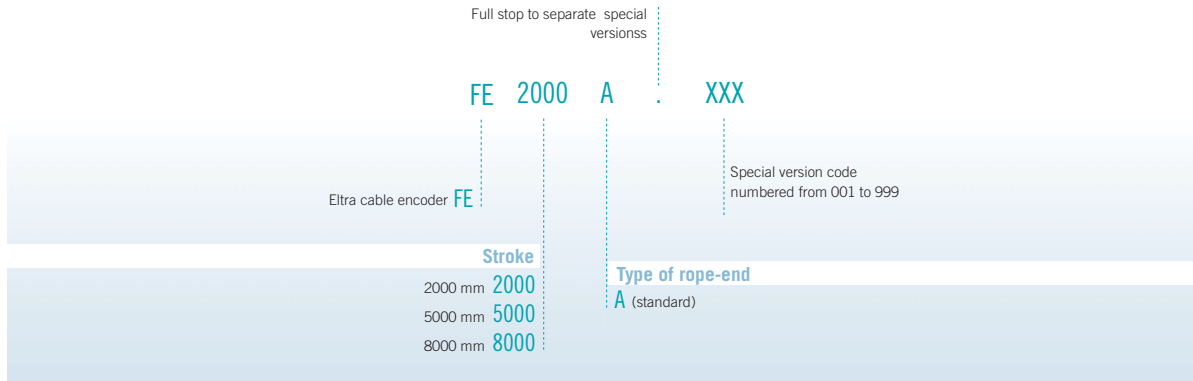

The encoder to be used in the FE model needs to be ordered separately. The "F" letter will be placed before the standard ordering code.

Example:

- 1- encoder model EH30M ordering code: FEH30M300S8/24P6X6PR
- 2- encoder model EL53B ordering code: FEL53B1100S5/28P6X3MR
- 3- encoder model EAM53B ordering code: FEAM53B16/4096G8/28PPX6X3MER

Complete ordering code example:

FE2000A-FEH30M300S8/24P6X6PR

FE

FE 2000

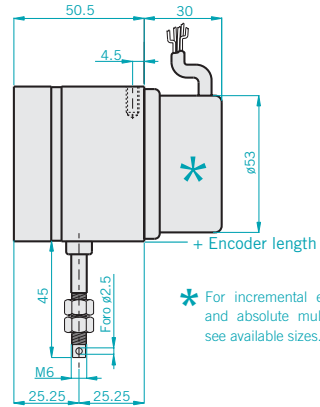
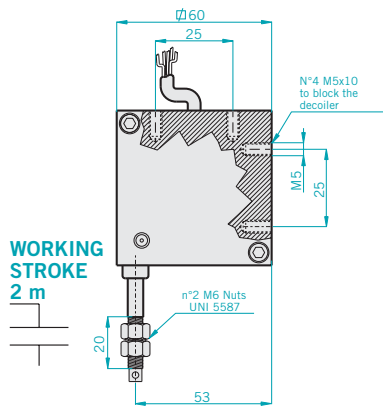

* For incremental encoder EL series and absolute multiturn EAM series see available sizes.

FE 5000

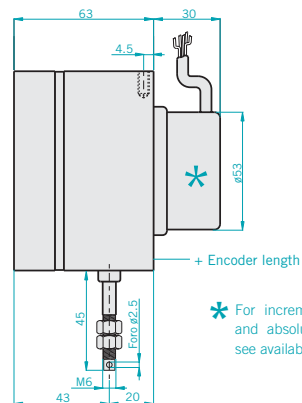
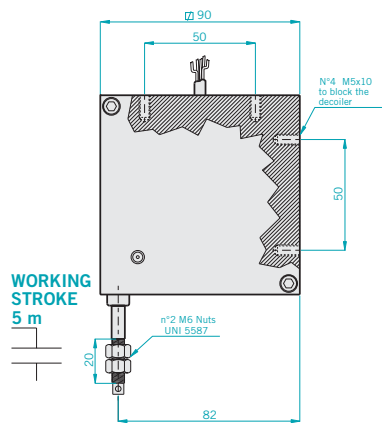

* For incremental encoder EL series and absolute multiturn EAM series see available sizes.

FE 8000

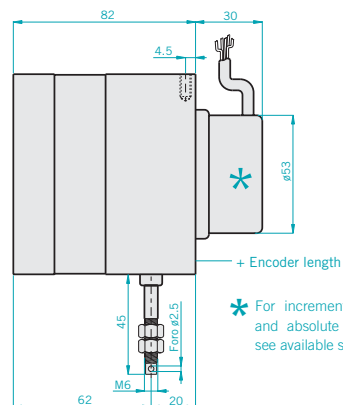
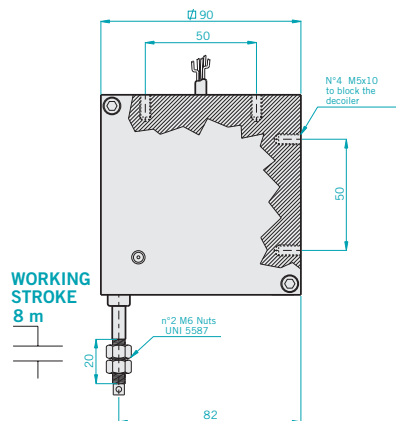

* For incremental encoder EL series and absolute multiturn EAM series see available sizes.



FEL 53B

High resolution incremental encoder with connector

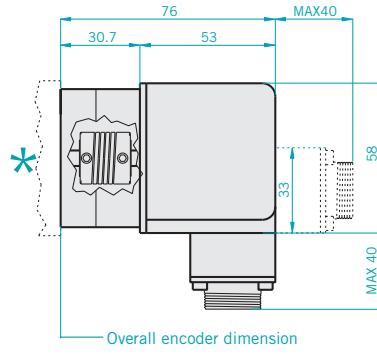

FEAM 53B

Multiturn absolute encoder applications

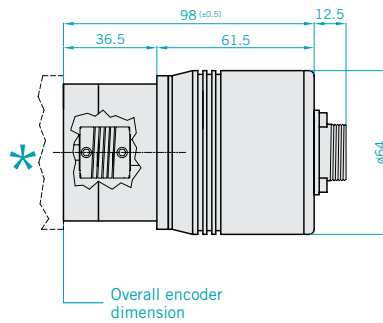
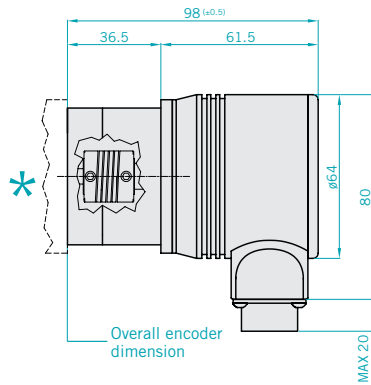

General resolutions specifications

Model	FE2000	FE5000	FE8000
One coil turn (mm)	120	220	220

Incremental encoder applications

Resolution	Pulses	Pulses	Pulses
1 mm	120	220	220
0,4 mm	300	550	550
0,1 mm	1200	2200	2200

For specific resolutions please contact our offices

Absolute encoder applications

Turn resolution	Pulses	Pulses	Pulses
1 mm	120	220	220
0,4 mm	300	550	550
0,1 mm	1200	2200	2200

In case of resolution split, output code will be independent concerning resolutions and turn number.

N° Turn	Turn	Turn	Turn
	16	22	36

For specific resolutions please contact our offices

Mechanical specifications

Linearity	+/-0,05%
Max Speed	50 m/min
Enclosure rating	IP54 standard
Vibrations	10G 10 ÷ 2000 Hz
Housing material	Aluminium
Rope material	Stainless steel
Operating temperature	0° ÷ +60°C
Storage temperature	-25° ÷ +70°C
Weight	-500g --FE2000 -1100g --FE5000 -1300g --FE8000

NOTE: for encoder specifications, refer to the technical cards of the following models:

- for EH30M see encoder EH38
- for EL53B see encoder EL53
- for EAM53B see encoder EAM58



ETMA MAGNETIC LINEAR SENSOR



SPECIAL PRODUCTS

ETMA1

Magnetic incremental linear sensor

- Resolution: 0,1 mm (0,025 mm if by reading each front)
- Zero pulse every 5 mm

ETMA2

Magnetic incremental linear sensor

- Resolution: 0,04 mm (0,01 mm if by reading each front)
- Zero pulse every 2 mm

Ordering code

Full stop to separate special versions

ETM A 1 Z 5 L S PR3 . XXX

Eltra magnetic incremental sensor **ETM**

Head type
horizontal **A**

Resolution
0,1 mm (0,025 by reading each front) **1**
0,04 mm (0,01 by reading each front) **2**

Zero pulse
with zero pulse every 5 mm on ETMA1
with zero pulse every 2 mm on ETMA2 **Z**

Input voltage
5V **5**
from 8V to 24V **8 ÷ 24**

Cable length
3 3 m (standard)
6 6 m
10 10 m
20 20 m

Enclosure rating
S standard IP67

Electronics output configuration
P PUSH PULL
L LINE DRIVER

Special version code numbered from 001 to 999

ETMA

ETMA

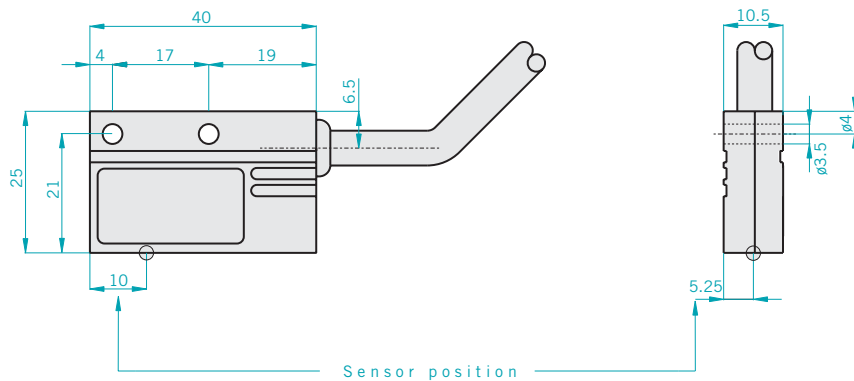

Sensor mechanical tolerances

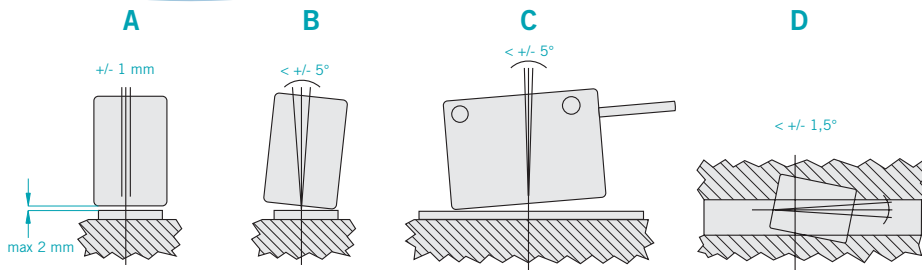

Electrical specifications

Resolution	0,1 mm (0,025 mm by reading each front) for ETMA1 0,04 mm (0,01 mm by reading each front) for ETMA2
Repeatability	+/- 0,025 mm
Output types	LINE DRIVER/PUSH PULL
Input voltage	5 Vdc 8÷24 Vdc
Input current with no output load	30 mA MAX
Zero pulse	with zero every 5 mm for ETMA1 with zero every 2 mm for ETMA2
Max speed	4 m/s
Frequency response	40 Khz

Wire colour

COLOUR	FUNCTION
RED	+Vdc
BLACK	0 Volt
GREEN	A
YELLOW	B
BLUE	Z
BROWN	\bar{A}
ORANGE	\bar{B}
WHITE	\bar{Z}



Mechanical specifications

Enclosure rating	IP67 - STANDARD
Shock	50G for 11msec
Vibrations	10G 10 ÷ 2000 Hz
Housing material	Aluminium
Fixing	n°2 hole $\varnothing 3,5$
Operating temperature	0° ÷ +60°C
Storage temperature	-25° ÷ +70°C
Max working distance	< 2 mm
Weight	150g

SPECIAL PRODUCTS

PV004IT0305A

ETMA





EBM MAGNETIC TAPE



Ordering code
Magnetic tape

Full stop to separate special versions

EBM A 1 - 10 . XXX

Eltra magnetic tape **EBM**

magnetic tape type **A**

magnetic resolution 0,1 mm **1**

magnetic resolution 0,04 mm **2**

Special version code
numbered from 001 to 999

Tape length

10 NOTE: meter multiples

- separate the code with a "-"

SPECIAL PRODUCTS

EBM

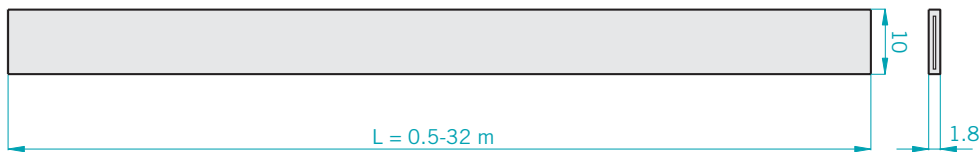

Different lengths available only on request.

Technical specifications

Operating temperature	0° ÷ +60°C
Precision (20°C)	+/- (0,025 + 0,02 x L) L= metric band length
Length expansion coefficient	16 x 10 ⁻⁶ m (m x °C)
Tape radius	150 mm minimum

EBM

Tape composition

As shown below, the Eltra magnetic tape is composed by three layers:

- 1 - A flexible magnetic tape made of plastic material
- 2 - A magnetised steel tape used to create a shield against any external magnetic disturb. Although, it's glued to the upper plastic layer in order to supply the correct mechanical consistency to the magnetic tape.
- 3 - The third part is the most rigid one and therefore is supplied separately due to transport and application needs. It must be stick to layer 1 by the user. The steel tape is magnetically neutral and employed to mechanically protect the magnetic tape.

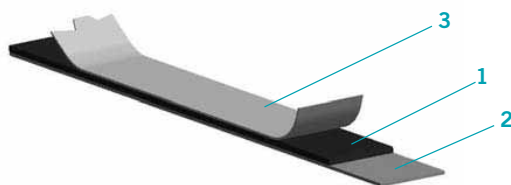

NOTE: To prevent damage from possible internal tensions in the magnetic tape, keep the tape rolled up with the magnetic part facing outwards with a minimum internal diameter of 300 mm.

Installation measures of the magnetic tape

Fixing pressure

The magnetic tape is adhesive. Therefore, it is important an optimum contact between surfaces for a correct application. A good pressure must be uniformly applied to guarantee a perfect result.

Gluing temperature

In order to guarantee an optimum adhesion it is preferable a surface temperature between 20° and 37° C. Maximum adhesion is obtained after 72 hours at a temperature of 21° C. We suggest to avoid applying the magnetic tape at a lower than 10° C surface temperature.

Application materials

For a correct adhesion the magnetic tape must be placed in dry, smooth and clean places. The surface must be cleaned with an alcohol-water solution at 50% or heptane. For appliances on brass, copper etc. the surface must be protected to prevent possible oxidation.

Chemical agents and magnetic tape behaviour

Null or irrelevant effect chemicals	Low or medium effect chemicals	Strong effect chemicals
Formic acid	Acetone	Benzene
Cotton seed oil	Acetylene	Laquer solvent
Formaldehyde 40%	Ammonia	Nitrobenzene
Glycerol 93°C	Gasoline	Nitric acid 70%
N-hexane	Vapor	Red nitric acid
Iso-octano	Acetic acid 20%	Nitric acid 37%, 93°C
Lin seed raw oil	Kerosene	Turpentin
Lactic acid	Acetic acid 30%, glacial acid	Carbon tetrachloride
Mineral acid	Isopropyl ether	Tetrahydrofuran
Soybean oil	Oleic acid	Toluene
	Sea water	Trichlorethylene
	Stearic acid 70%	Dimethylbenzene



EP A/B POTENTIOMETER



Potentiometer
EP series

Encoders with potentiometric output signal. The potentiometer is sealed in a robust cover and it is supported by two bearings. It assures excellent lifetime, speed and precision performances.



SPECIAL PRODUCTS

Ordering code

EP A 103/10 P R . XXX

Full stop to separate special versions

Special version code numbered from 001 to 999

A axial
R radial

P Cable output (standard length 1.5 m)

Resistivity

502/1 5 Kohm/1 turns (mod. A)
502/3 5 Kohm/3 turns (mod. B)
103/1 10 Kohm/1 turns (mod. A)
103/3 10 Kohm/3 turns (mod. B)
103/10 10 Kohm/10 turns (mod. A)

Shaft type

A mod. EP A \varnothing 10 shaft
B mod. EP B toothed shaft

EP Eltra's potentiometer

EP A/B

EP A

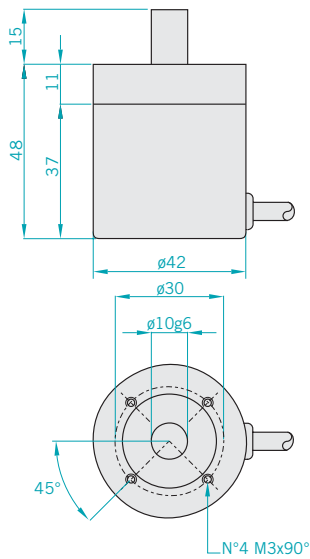

EP B

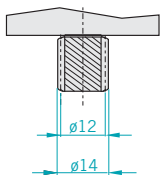
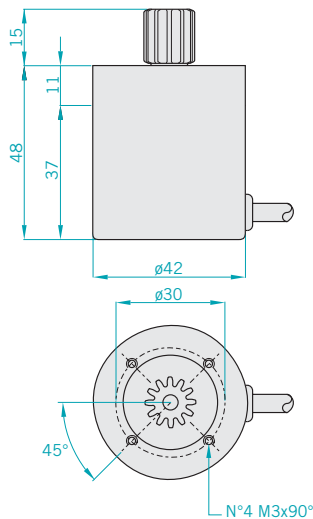

TOOTH SPECIFICATIONS

z = 12
m = 1
p = 3.1415

General specifications

Available potentiometers	5 Kohm/1 turn (mod.A) 5 Kohm/3 turns (mod.B) 10 Kohm/1 turn (mod.A) 10 Kohm/3 turns (mod.B) 10 Kohm/10 turns (mod.A)
Tolerance	± 5%
Linearity	± 0.25%
Power rating (70°C)	model A: 2.0 watt model B: 1.0 watt
Lifetime	300.000 for model B 1.000.000 for model A
Shock	50G for 11 msec
Vibrations	15G 10÷2000 Hz
Shaft diameter	ø10 g6
Shaft material	Stainless steel AISI303
Toothed shaft specifications	Z= 12/m= 1/p= 3.1415
Toothed shaft material	Steel C45
Housing material	PA 66 reinforced with fiber glass
Body material	Aluminium UNI 900/5
Bearings	n° 2 ball bearings
Weight	150g

Colours and connections

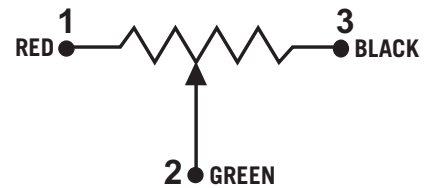

Operating specifications

Enclosure rating	IP54 Standard
Operating temperature	0° ÷ +60°C
Storage temperature	-25° ÷ +70°C

Working diagram and terminal board connection

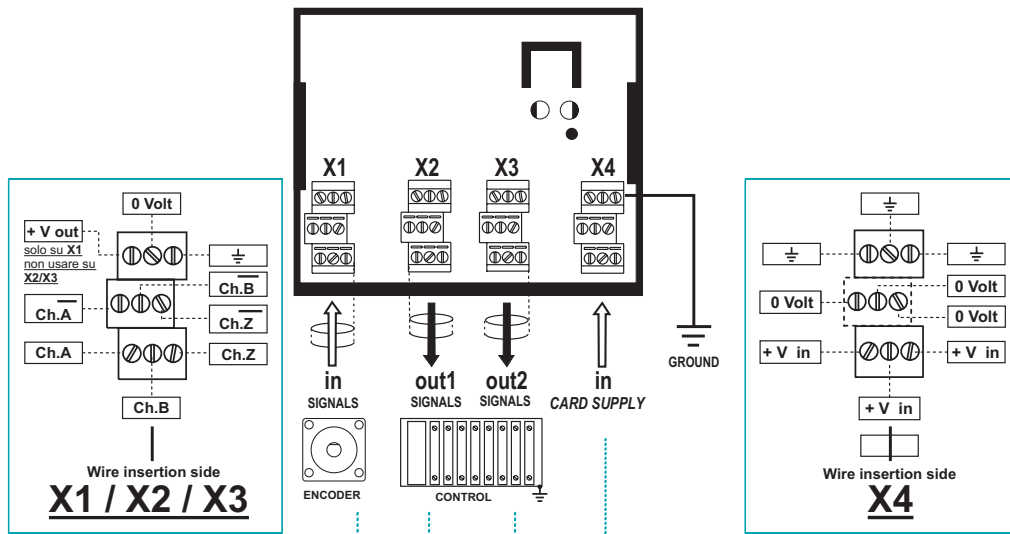

TERMINAL BOARDS CONNECTION SIGNALS

TERMINAL BOARD CONNECTION AND POWER SUPPLY

Usage examples

EMB ADAPTATION OF ELECTRONIC SIGNALS

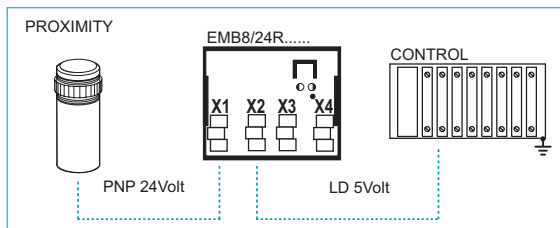

EMB AS INTERMEDIATE SIGNAL AMPLIFIER

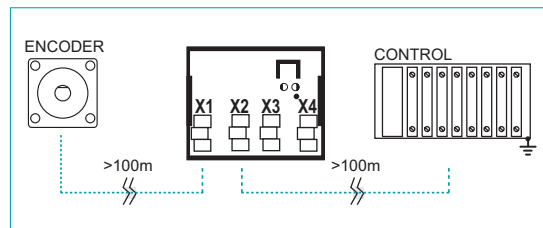

Ordering code

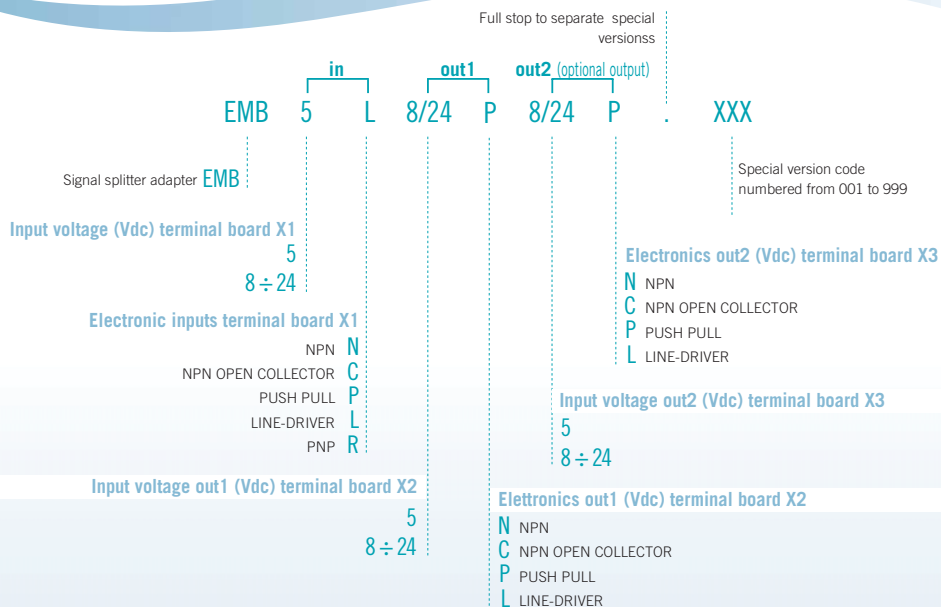

Electrical specifications

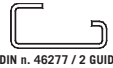
Input voltage	5 Vdc / 8÷24 Vdc
Input current with no output load	150 mA
Max output current per channel	20 mA LINE DRIVER 40 mA PUSH PULL
Max input current per channel	10 mA
Frequency response	100 KHz
Operating temperature	0° ÷ +40°C
Logic input levels IN1 and IN2 (Vdc)	"0" = 5÷24 "1" = 0÷3
Free contact characteristics	Vmax= 125 Vac/ 60 Vdc Imax= 0.5A Vmin= 5 Vdc Imin= 1mA
Fixing on frame	  DIN n. 46277 / 3 GUIDE (OMEGA) DIN n. 46277 / 2 GUIDE

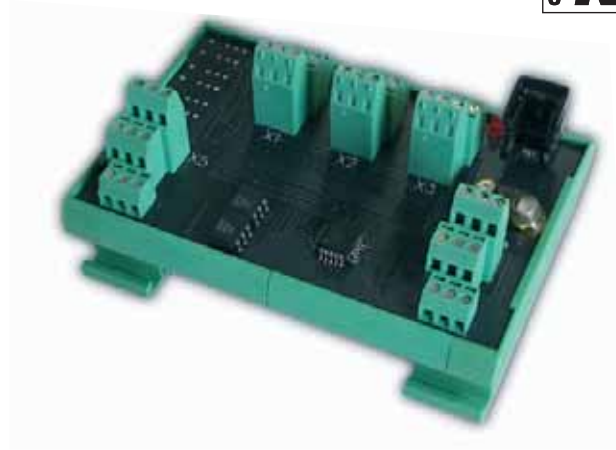
The EMD board

This board is used when is necessary to carry out a selected signal among a maximum of three inputs

The EMD board accepts as input signals coming from a maximum of three encoders and supplies as output the signals electronically selected of one of these.

The output signal is selected by opportunely supplying the two inputs, IN1 and IN2, according to the working diagram (see back side).

Output and encoder type to be connected have to be within the range described in the ordering code. All electronic types of the connected encoders have to be the same. Moreover, the EMD supplies three contacts normally open switching to close when the respective input is selected.

In order to better understand the use of this board the following example is provided.

We would like to realize a device reading three encoders input (or other sensors with compatible characteristics), in a sequential way. Encoders have to be chosen featuring the same electronics output, for example 5 Vdc line-driver. Instead, the device can acquire data with another electronic type; for example 24 Vdc push-pull.

In this case the EMD board realizes the commutation function of the connected encoders and adapts the electronics of those with the one required from the instrument.

The ordering code will be:

EMD5L8/249

5L indicates that inputs are 5 Vdc line-driver. **8/24P** indicates that the output is with push-pull electronics and with an input voltage from 8 to 24 Vdc. The board input voltage has to be the highest between the requested: in this case 8/24 Vdc. The encoder commutation happens through a logic type signal at the IN1 and IN2 inputs on the Xn terminal board.

The logic level "1" is obtained by connecting the above mentioned inputs to a voltage included between +5 and +24 Vdc.

Instead, for the "0" level, the voltage must be between 0 and +3 Vdc. The combination of the logic levels at IN1 and IN2 configures the terminal board of output in 4 different mode as described in the table in the following page.

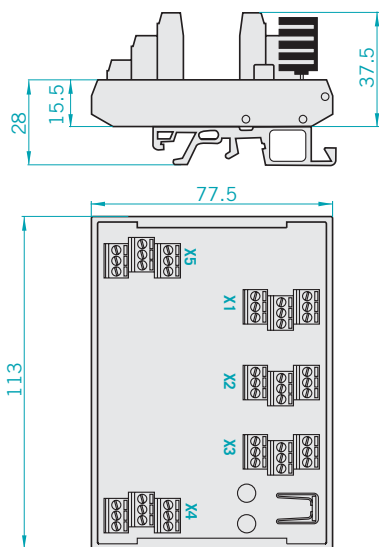
Overall dimension

Working diagram and terminal connections board

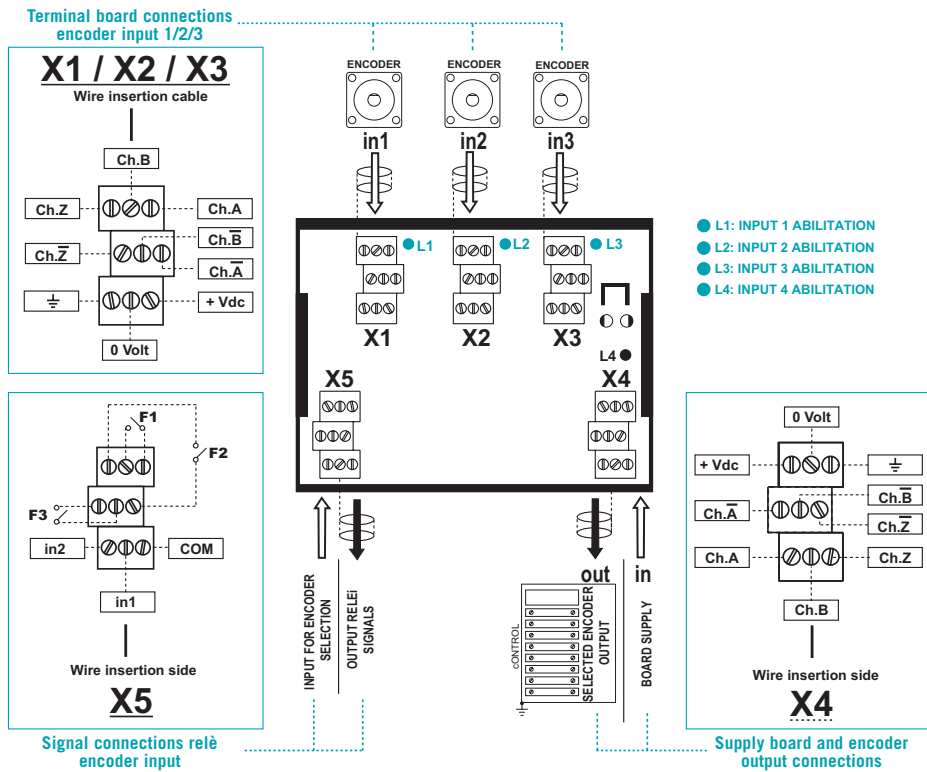

Logic status table

The table indicates the output status on the X4 connector and on the free contacts on X5, according to the logics status present on in1 and in2 on the X5 terminal board.

Logic status on X5		Encoder selected on X4			Contact selected on X5		
in1	in2	X1	X2	X3	F1	F2	F3
0	0	—	—	—	—	—	—
1	0	●	—	—	●	—	—
0	1	—	●	—	—	●	—
1	1	—	—	●	—	—	●

Ordering code

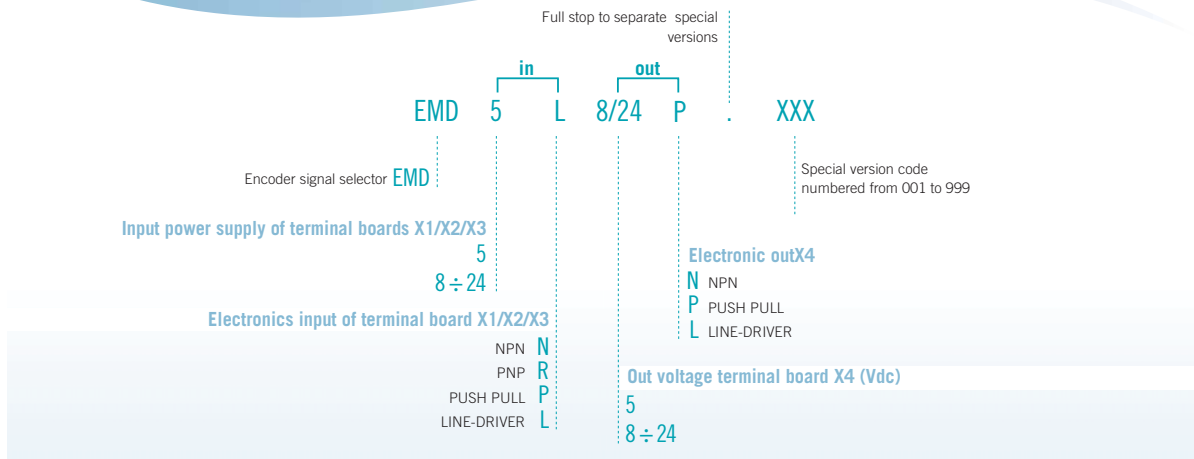



PRECISION ELASTIC COUPLINGS



Elastic Couplings

Ordering Code

ELTRA elastic precision couplings are essential parts for the transmission of rotational motion to the encoder shaft. Couplings are designed in aluminium alloy (type D11S A.A 2011) and are composed by a cylindrical body on which there is an helicoidal groove.

Main characteristics are:

- torsional rigidity
- ability to support slight shaft misadjustments
- ability to absorb small axial shift of the shaft.

ELTRA elastic couplings have also a perfect balancing of the rotating body. They don't have critical points subjects to breakage and are completely frictionless. Moreover, they perfectly transmit the rotation motion, even in case of axial misadjustment and misalignment. Our coupling do not require any type of maintenance. The internal drain allows the coupling between the shafts from a minimum of 0.5mm to a maximum of 6.12mm (note "F" quota).

NOTE: Elastic Coupling can be supplied with different coupling diameters. Eg: d1=8mm, d2=10mm. In this case the identification code should be: G25A8/10.

G 25 A 6 / 8

Precision elastic Coupling G

Coupling size

- (see table) 16
- (see table) 20
- (see table) 25
- (see table) 30

Shaft dowel fixing

A

∅ hole "d1"

- ∅ 6 6
- ∅ 8 8
- ∅ 9.52 (3/8") 9
- ∅ 10 10

∅ hole "d2"

- ∅ 6 6
- ∅ 8 8
- ∅ 9.52 (3/8") 9
- ∅ 10 10

NOTE: if d1 is equal to d2 that is not necessary

SPECIAL PRODUCTS

ELASTIC COUPLINGS

Construction data and specifications

Type of material:
Aluminium

NOTE: for non standard (d1-d2) please contact our offices.



Standard Couplings	De	L	d1 = d2	A	B	M	E	F	Twisting moment
G 16 A 4	∅ 16	20 ^{+0.1} / _{-0.1}	∅ 4H7 ^{+0.012} / ₀	6	8	M3	7	6	0.25 Nm
G 20 A 6	∅ 20	20 ^{+0.1} / _{-0.1}	∅ 6H7 ^{+0.012} / ₀	6	8	M3	7	6	0.25 Nm
G 25 A 8	∅ 25	25 ^{+0.1} / _{-0.1}	∅ 8H7 ^{+0.015} / ₀	7	11	M4	8	9	0.4 Nm
G 25 A 9	∅ 25	25 ^{+0.1} / _{-0.1}	∅ 9.52H7 ^{+0.015} / ₀	7	11	M4	8	9	0.4 Nm
G 25 A 10	∅ 25	25 ^{+0.1} / _{-0.1}	∅ 10H7 ^{+0.015} / ₀	7	11	M4	8	9	0.4 Nm
G 30 A 10	∅ 25	30 ^{+0.1} / _{-0.1}	∅ 10H7 ^{+0.015} / ₀	8	14	M4	9	12	0.4 Nm

NOTE FOR THE INSTALLER: it is suggested to respect quotes inserting shaft on the coupling

Couplings dimensions

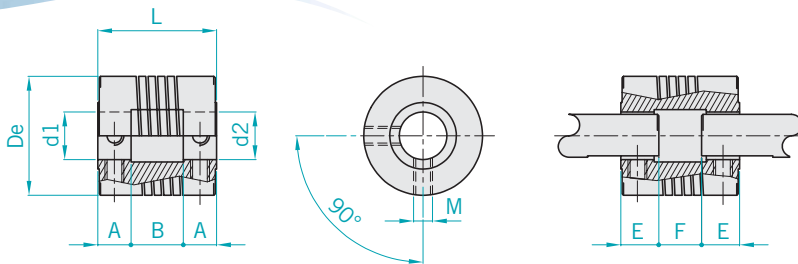

Construction data and specifications



Ordering Code	De	L	d1 = d2	A	B	M	E	F	Twisting moment
GS 02A 6	∅ 19.1	22 ^{+0.1} / _{-0.1}	∅ 6H7 ^{+0.012} / ₀			M3	6.3		0.9 Nm
GS 10A 8	∅ 19.1	22 ^{+0.1} / _{-0.1}	∅ 8H7 ^{+0.012} / ₀			M3	6.3		0.9 Nm
GS 16A 10	∅ 19.1	22 ^{+0.1} / _{-0.1}	∅ 10H7 ^{+0.012} / ₀			M3	6.3		0.9 Nm
GS 01A 8	∅ 19.1	28 ^{+0.1} / _{-0.1}	∅ 8 ^{+0.012} / ₀			M3	8		0.35 Nm
GS 11A 10	∅ 19.1	28 ^{+0.1} / _{-0.1}	∅ 10H7 ^{+0.012} / ₀			M3	8		0.35 Nm
GS 15A 10	∅ 19.1	47 ^{+0.1} / _{-0.1}	∅ 10H7 ^{+0.012} / ₀			M4	12.6		0.1.4 Nm
GS 23A 12	∅ 19.1	47 ^{+0.1} / _{-0.1}	∅ 12H7 ^{+0.012} / ₀			M4	12.6		1.4 Nm
GS 29A 6	∅ 25	32 ^{+0.1} / _{-0.1}	∅ 6H7 ^{+0.012} / ₀			M3	10		3 Nm
GS 24A 8	∅ 25	32 ^{+0.1} / _{-0.1}	∅ 8H7 ^{+0.012} / ₀			M3	10		3 Nm
GS 25A 10	∅ 25	32 ^{+0.1} / _{-0.1}	∅ 10H7 ^{+0.012} / ₀			M3	10		3 Nm

NOTE FOR THE INSTALLER: For a proper installation is suggested to insert shaft on the coupling respecting quotes

Eltra also produces a special coupling series designed especially for critic and heavy uses. On the table below are shown some special couplings available on stock. Different couplings available only on request.

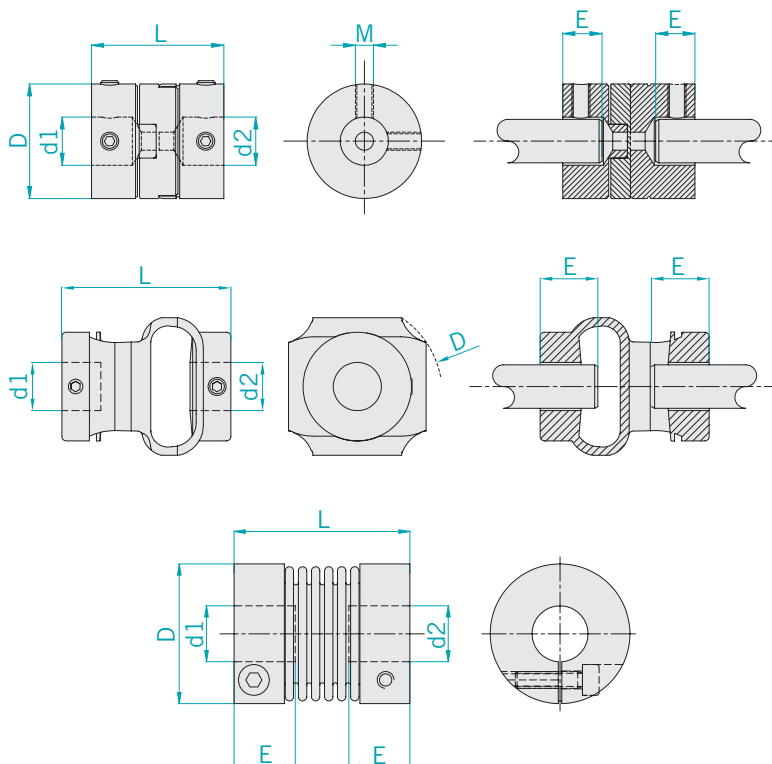

OUTPUT CONFIGURATIONS AND CONNECTIONS



NPN and NPN OPEN COLLECTOR electronic

It is composed only by an NPN transistor and a pull-up resistor used to match the output voltage to the power supply when the transistor is quiescent. From the electrical point of view it is similar to TTL type logic and so it is considered compatible. If used correctly, it shows low saturation levels at 0 Vdc and close to 0 at the positive. It is proportionally influenced by the cable length, pulses frequency and by the load.

Please consider these specs for a proper use. The open collector variant is different for the lack of the pull-up resistor, freeing in such way the transistor collector from the tie of the encoder power supply allowing to obtain signals with different voltage.

NPN OPEN COLLECTOR

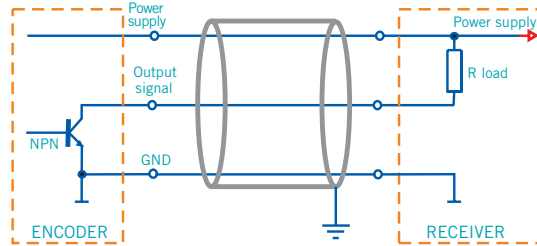

NPN

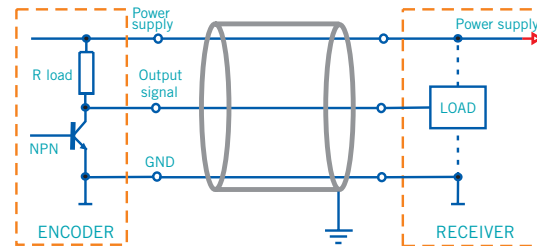

PNP OPEN COLLECTOR

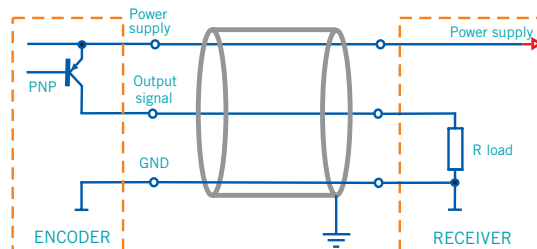

PNP

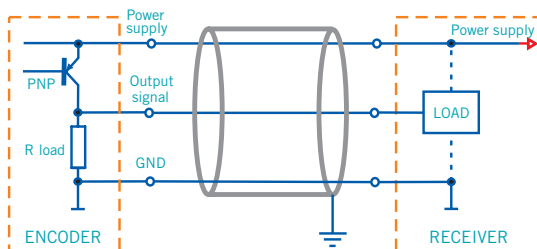

PNP and PNP OPEN COLLECTOR electronic

Main characteristics and limitations are the same as for NPN electronics. Main difference is the transistor, which is of PNP type and is constrained to the positive. The resistor, if present, is a pull-down one. Therefore, it is connected between the output and zero Vdc.

PUSH-PULL

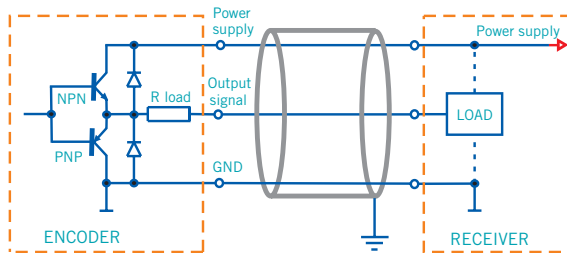

PUSH-PULL electronic

Electronic featuring high performances. NPN or PNP major limitations are caused by the resistor, which works with a much higher impedance than a transistor. To overcome this issue, push-pull electronic uses a complementary transistor, so the impedance is lower for commutation to positive and to zero. This solution increases frequency performances allowing longer cable connections and an optimal data transmission even at high working speed. Saturation signals are low but sometimes higher than in NPN and PNP electronics. Anyway, PUSH-PULL electronics is in any case indifferently applicable instead of NPN or PNP.

LINE DRIVER

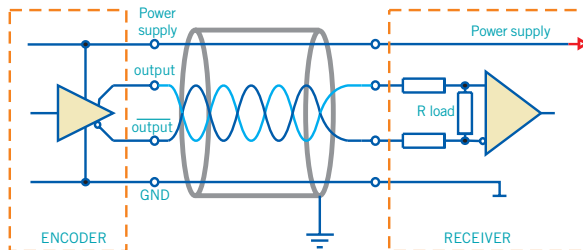

LINE DRIVER electronic

LINE DRIVER is used when operating environments are particularly exposed to electrical disturbances or when the encoder is quite far from the receiver system. Data transmission and receiving work on two complementary channels so disturbances are limited (they usually come from other cables or close machinery). These interferences are known as «common way disturbances» as their generation is due to a common point: the system mass. Instead, in LINE-DRIVER transmitted and received signals work in «differential» way. In other words, it works basing the communication on voltage differences between complementary channels. Therefore it is not effective to common way disturbances. This type of transmission is used in 5 Vdc systems and it is also known as RS422 compatible. It is available with power supplies up to 24 Vdc

PROTECTIONS

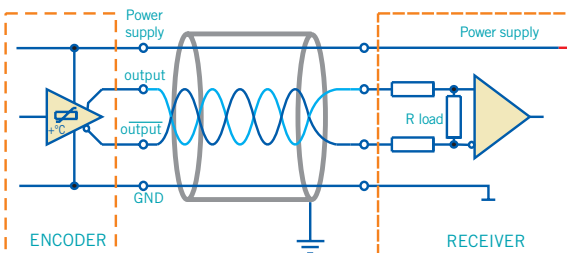
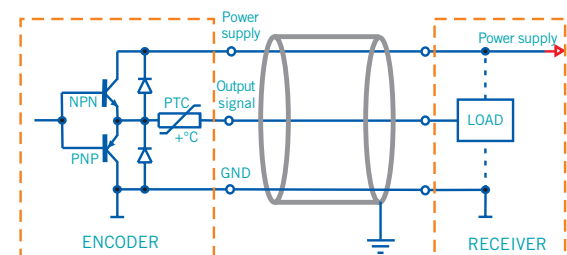

Protection for output stages

Two different kind of electronic protection against short circuits might be used: the passive one (using fuses, no linear resistors, etc.) and active one (using transistors). Eltra's encoders can be equipped with both type of protection against short circuits

Passive protection

Passive solution is the cheapest one. It is used to avoid accidental short circuits, which rarely happens. The component which carries out the protection is called PTC. It is a resistor that, if crossed by a voltage exceeding the supposed one, increases its resistance to limit electricity exceedance. Limitations of this kind of protection concern the low reacting speed, which may progressively stress the components under protection. Therefore, this protection is effective against a limited number of short circuits and it is available only for NPN, PNP, and PUSH-PULL electronics.

Active protection

This solution is based on a circuit integrated in the electronic output which constantly controls the temperature reached by the element to be protected. In this way, protection is very effective and the reacting speed very high. Moreover, it ensures a constant protection against repetitive and permanent short circuits, that is why is strongly suggested for heavy usages. It is available only for LINE-DRIVER and PUSH-PULL electronics.

NPN/NPN OPEN COLLECTOR TTL OR PUSH-PULL

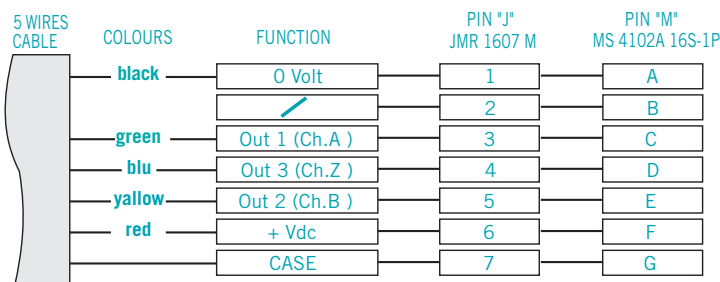

LINE DRIVER without ZERO

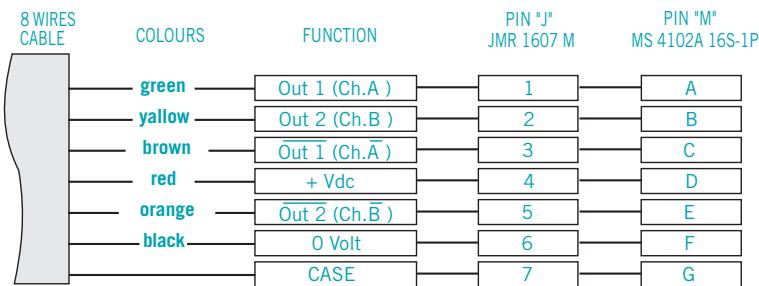

LINE DRIVER with ZERO

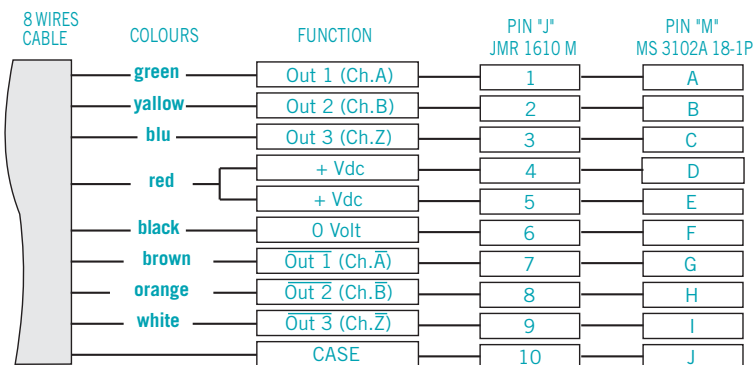

PRECAUTIONS AGAINST ELECTROSTATIC DICHARGES

Be sure the metallic connector is connected to the ground through a ring fixed to the screw of the connector itself (Fig. 1)

Fig. 1



Ground connect to the shield and the connector case (Fig. 2)

Fig. 2



For a better protection of the electronics against electrostatic discharges connect the metallic connector case to ground

Cable proper use

- Ensure a ground connection to the cable shield avoiding to connect it to the power ground.
- Keep the encoder cable (signal cable) to a proper distance from the power ones.
- Choose the cable's length according to installation requirements.
- Spread the cable avoiding spirals.

News

- Cable extensions and connectors could be designed on demand
- Testing on 100% of the production
- Antivibration wiring system
- **Contact us for further information**

Cables availability

POLES N°	CEI	IEC MARK	UL MARK	SHIELD	TYPE
5	CEI 20-22 II			FOIL	SEMIRIGID
		IEC 60332-1	UL-CSA	BRAID	FLEXABLE
	IEC 60332-1		UL-CSA	FOIL	SEMIRIGID
	CEI 20-22 II	IEC 60332.3		BRAID	SEMIRIGID
8	CEI 20-22 II			FOIL	SEMIRIGID
	CEI 20-22 II			BRAID	SEMIRIGID
		IEC 60332-1	UL-CSA	BRAID	FLEXABLE
		IEC 60332-1		FOIL	SEMIRIGID
	CEI 20-22 II	IEC 60332.3		BRAID	SEMIRIGID
10	CEI 20-22 II			BRAID	SEMIRIGID
12	CEI 20-22 II			FOIL	SEMIRIGID
16	CEI 20-22 II			FOIL	SEMIRIGID
32	CEI 20-22 II			FOIL	SEMIRIGID

NOTE: Please, directly contact our offices for non-standard cables availability

SV011T0305A

INCREMENTAL ENCODER CONNECTIONS



INSTALLATION AND OPERATION PRECAUTIONS



The encoder must be used with respect to its specifications. Encoder is a pulse generator and not a safety device



Assembling and installing personnel must be qualified and carefully follow instructions of technical manual.



Don't expose the device to stress or impacts in order to ensure the correct working otherwise the warranty expires



Make sure that the mechanical coupling of the encoder shaft is designed with the appropriate elastic couplings, especially in the case of accentuated axial or radial movements



Make sure that the environment of use is free of corrosive agents (acids, etc.) or substances that are not compatible with the device



Check the ground connection of the device if it is not possible to provide additional external connection.



Before putting it in operation, verify the voltage range applicable to the device and protect it from exceeding the stated technical specifications.



Connect power supply and signals cables in order to avoid capacitive or inductive interferences that may cause malfunction of the device.



Cable wiring must be carried out in a POWER-OFF condition



For safety reasons, we strongly recommend to avoid any mechanical or electrical modification. In that case, they will void the warranty

Main product warranty terms

Replacements or repairs whether under the warranty or at the customer's expense must be performed in the service department of Eltra Srl or by explicitly authorized personnel. Before sending material for repairing, you must obtain an RGA number from our sales office. During the repair process in our service department, Eltra srl will be authorized to remove all parts that the customer added to the product. Any malfunction due to a failure to observe these usage and installation precautions will lead to the warranty voiding. Repairs will not extend the product warranty. We also exclude compensation for any type of damage or injury due to the use, or suspension of use, of the transducer.

Note: for additional information, refer to the sale terms on our website, www.eltra.it, or call our office.



...IN THE WORLD

SV012IT0305A

- ARGENTINA
- AUSTRALIA
- BRAZIL
- CHILE
- ▲ CHINA
- EGYPT
- HONG KONG
- INDIA
- ISRAEL
- MEXICO
- NEW ZELAND
- RUSSIA
- SOUTH AFRICA
- TAIWAN
- ▲ USA
- ▲ ITALY

- AUSTRIA
- BELGIUM
- BULGARIA
- FINLAND
- FRANCE
- GERMANY
- GREECE
- GREAT BRITAIN
- THE NETHERLANDS
- POLAND
- CZECH REPUBLIC
- ▲ REPUBLIC OF SLOVAKIA
- SPAIN
- SVEDEN
- TURKEY
- HUNGARY

